

# ACUTO

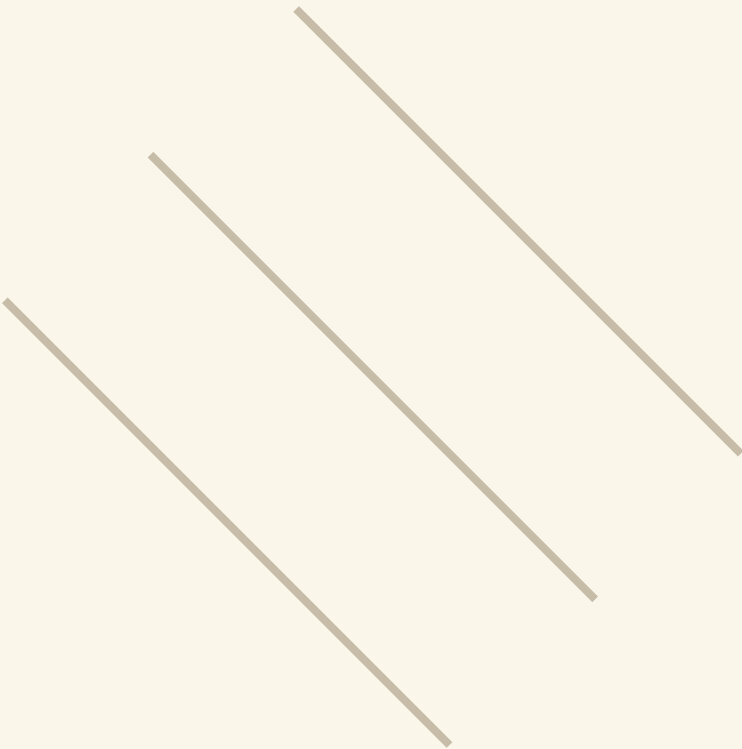

# INDEX

01 ACUTO / PURO	006 / 015
02 ACUTO / MIDI	016 / 025
03 ACUTO / PURO	026 / 035
04 ACUTO / PURO	036 / 045
05 ACUTO / MIDI	046 / 055
06 ACUTO / PURO	056 / 065
07 ACUTO / PURO	066 / 075
08 ACUTO / PURO	076 / 085
09 ACUTO / PURO	086 / 095
10 ACUTO / MIDI	096 / 105
11 ACUTO / PURO	106 / 115
12 ACUTO / PURO	116 / 127
13 ACUTO / MIDI	128 / 137
14 ACUTO / PURO	138 / 147
15 ACUTO / DUAL	148 / 159
16 ACUTO / PURO	160 / 169
17 ACUTO / DUAL	170 / 179
18 ACUTO / PURO	180 / 189
19 ACUTO / MIDI	190 / 199
20 ACUTO / DUAL	200 / 209
<b>FINISHING</b>	210 / 227
<b>COMPOSITIONS</b>	228 / 231

# ACUTO

IT ACUTO HA UN SEGNO DECISO, ESSENZIALE, CONTEMPORANEO. L'APERTURA A GOLA DECLINATA IN TRE CONFIGURAZIONI, DÀ RITMO ALLA COMPOSIZIONE E VALORIZZA L'ESPERIENZA D'USO. L'ASSENZA DI MANIGLIA ESALTA LA PUREZZA DELLE FORME, CON INTAGLI A 45° TRA FIANCHI E FRONTALI.

EN Acuto has a bold, essential, contemporary design. The recessed handle, available in three configurations, adds rhythm to the composition and enhances the user experience. The absence of handles emphasizes the purity of the forms, with 45° mitered joints between side panels and fronts.

DE Acuto hat eine klare, essenzielle, zeitgemässe Formensprache. Die Griffmulde, in drei Varianten erhältlich, verleiht der Komposition Rhythmus und wertet das Nutzererlebnis auf. Der Verzicht auf Griffe betont die Reinheit der Formen, mit 45°-Gehrungsschnitten zwischen Seitenteilen und Fronten.

FR Acuto a une ligne nette, essentielle et contemporaine. L'ouverture par gorge, déclinée en trois configurations, donne du rythme à la composition et valorise l'expérience d'utilisation. L'absence de poignée exalte la pureté des formes, avec des coupes à 45° entre les côtés et les façades.

# ACUTO

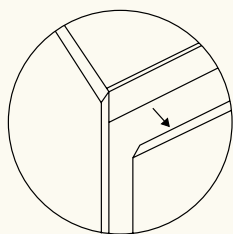
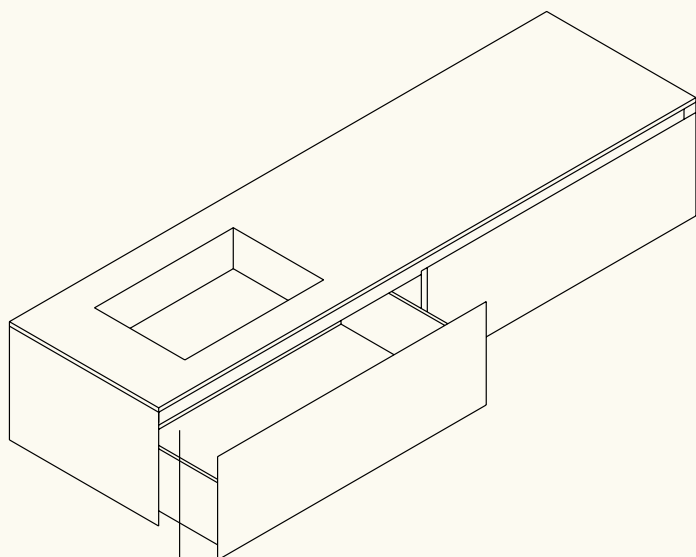

**IT** L'elemento caratterizzante di ACUTO è rappresentato dall'apertura attraverso una comoda sagomatura a 45° del frontale. Un ulteriore elemento estetico che definisce la collezione è il raccordo a 45° tra il frontale stesso e il fianco laterale del mobile o della composizione.

**EN** The distinctive element of ACUTO is its opening system created through a practical 45° shaping of the front panel. A further aesthetic feature that defines the collection is the 45° joint between the front panel itself and the side panel of the cabinet or composition.

**DE** Das charakteristische Element von ACUTO ist die Öffnung die durch eine praktische 45°-Ausformung der Front realisiert wird. Ein weiteres ästhetisches Merkmal, das die Kollektion definiert, ist die 45°-Verbindung zwischen der Front selbst und dem Seitenteil des Möbels oder der Komposition.

**FR** L'élément distinctif de ACUTO est son ouverture réalisée grâce à un façonnage pratique à 45° de la façade. Un autre élément esthétique qui définit la collection est le raccord à 45° entre la façade elle-même et le côté du meuble ou de la composition.

# FINITURE

Finishing / Finitions / Ausführungen

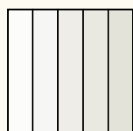

## **laccato opaco**

Matt lacquered  
Matt lackiert  
Laqué mat

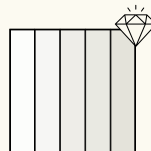

## **laccato lucido**

Glossy lacquered  
Glänzend lackiert  
Laqué brillante

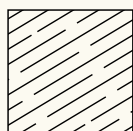

## **decorativo melaminico**

Decor  
Holzdekor  
Décor bois



## **legno impiallacciato**

Wood veneer  
Echtholz furnier  
Placage bois

Per la lista completa delle finiture, consultare da pag. 210 / For the complete list of finishes, refer to page 210 / Für die vollständige Liste der Ausführungen siehe Seite 210 / Pour la liste complète des finitions, consulter à partir de la page 210.

# ACUTO

Sistemi di apertura / Opening Systems / Öffnungssysteme /  
Systèmes d'ouverture

**IT** La gamma Acuto è disponibile in tre configurazioni, pensate per definire in modo preciso estetica e funzionalità del sistema: Dual, Puro e Midi.

**Le collezioni garantiscono un'ampia modularità progettuale, con basi, ante, vani a giorno e altri elementi coordinati, completati da pensili e colonne per una composizione completa e coerente.**

**EN** The Acuto range is available in three configurations, designed to precisely define the aesthetics and functionality of the system: Dual, Puro and Midi.

The collections ensure extensive design modularity, with base units, doors, open compartments and other coordinated elements, completed by wall units and tall units for a complete and coherent composition.

**DE** Die Produktlinie Acuto ist in drei Konfigurationen erhältlich, die entwickelt wurden, um Ästhetik und Funktionalität des Systems präzise zu definieren: Dual, Puro und Midi.

Die Kollektionen gewährleisten eine hohe planerische Modularität mit Unterschränken, Türen, offenen Fächern und weiteren abgestimmten Elementen, ergänzt durch Hängeschränke und Hochschränke für eine vollständige und stimmige Komposition.

**FR** La gamme Acuto est disponible en trois configurations, conçues pour définir avec précision l'esthétique et la fonctionnalité du système : Dual, Puro et Midi.

Les collections garantissent une large modularité de conception, avec des meubles bas, des portes, des niches ouvertes et d'autres éléments coordonnés, complétés par des meubles hauts et des colonnes pour une composition complète et cohérente.

## DUAL

- IT **Gola superiore e – nel caso di doppio o triplo cassetto – anche intermedia, per un'apertura ergonomica e confortevole.**
- EN Upper groove and – in the case of double or triple drawer units – also intermediate, for ergonomic and comfortable opening.
- DE Obere Griffmulde und – bei Doppel- oder Dreifachschubladen – auch mittlere, für eine ergonomische und komfortable Öffnung.
- FR Prise de mains supérieure et – dans le cas de double ou triple tiroir – également intermédiaire, pour une ouverture ergonomique et confortable.

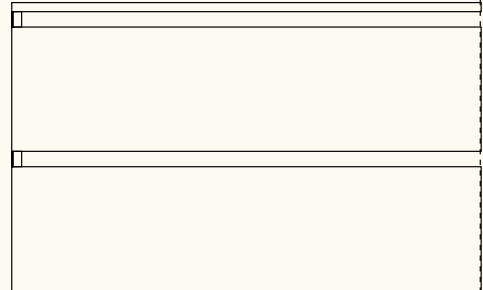

## PURO

- IT **Puro privilegia la purezza estetica. Solo gola superiore, apertura cassetti inferiori dal basso. Si privilegia la pulizia estetica e formale senza rinunciare alla comodità.**
- EN Puro emphasizes aesthetic purity. Upper groove only, with lower drawers opened from below. A clean and formal design is prioritized without sacrificing comfort.
- DE Puro stellt die ästhetische Reinheit in den Vordergrund. Nur obere Griffmulde, Öffnung der unteren Schubladen von unten. Die formale und gestalterische Klarheit wird betont, ohne auf Komfort zu verzichten.
- FR Puro privilégie la pureté esthétique. Uniquement prise de mains supérieure, ouverture des tiroirs inférieurs par le bas. La pureté esthétique et formelle est privilégiée sans renoncer au confort.

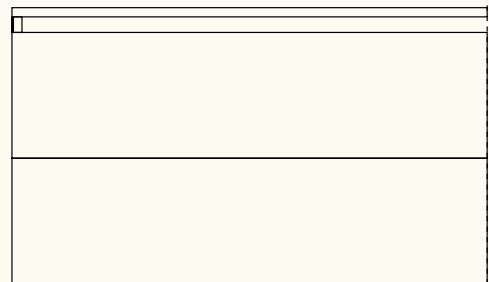

## MIDI

- IT **Gola centrale, per un equilibrio formale che unisce praticità e pulizia compositiva.**
- EN Central groove, for a formal balance that combines practicality and compositional clarity.
- DE Mittlere Griffmulde, für ein formales Gleichgewicht, das Funktionalität und gestalterische Klarheit vereint.
- FR Prise de mains centrale, pour un équilibre formel qui allie praticité et pureté compositionnelle.

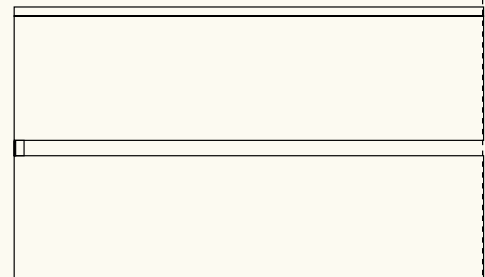



# 01 ACUTO / PURO

IT IL MARMO TROVA CONTINUITÀ  
NATURALE ACCANTO AL LEGNO,  
IN UN INSIEME SEMPLICE E RAFFINATO.

EN Marble finds a natural continuity alongside wood, in a simple and refined composition.

DE Marmor findet eine natürliche Kontinuität neben dem Holz, in einem schlichten und raffinierten Gesamtbild.

FR Le marbre trouve une continuité naturelle aux côtés du bois, dans un ensemble simple et raffiné.

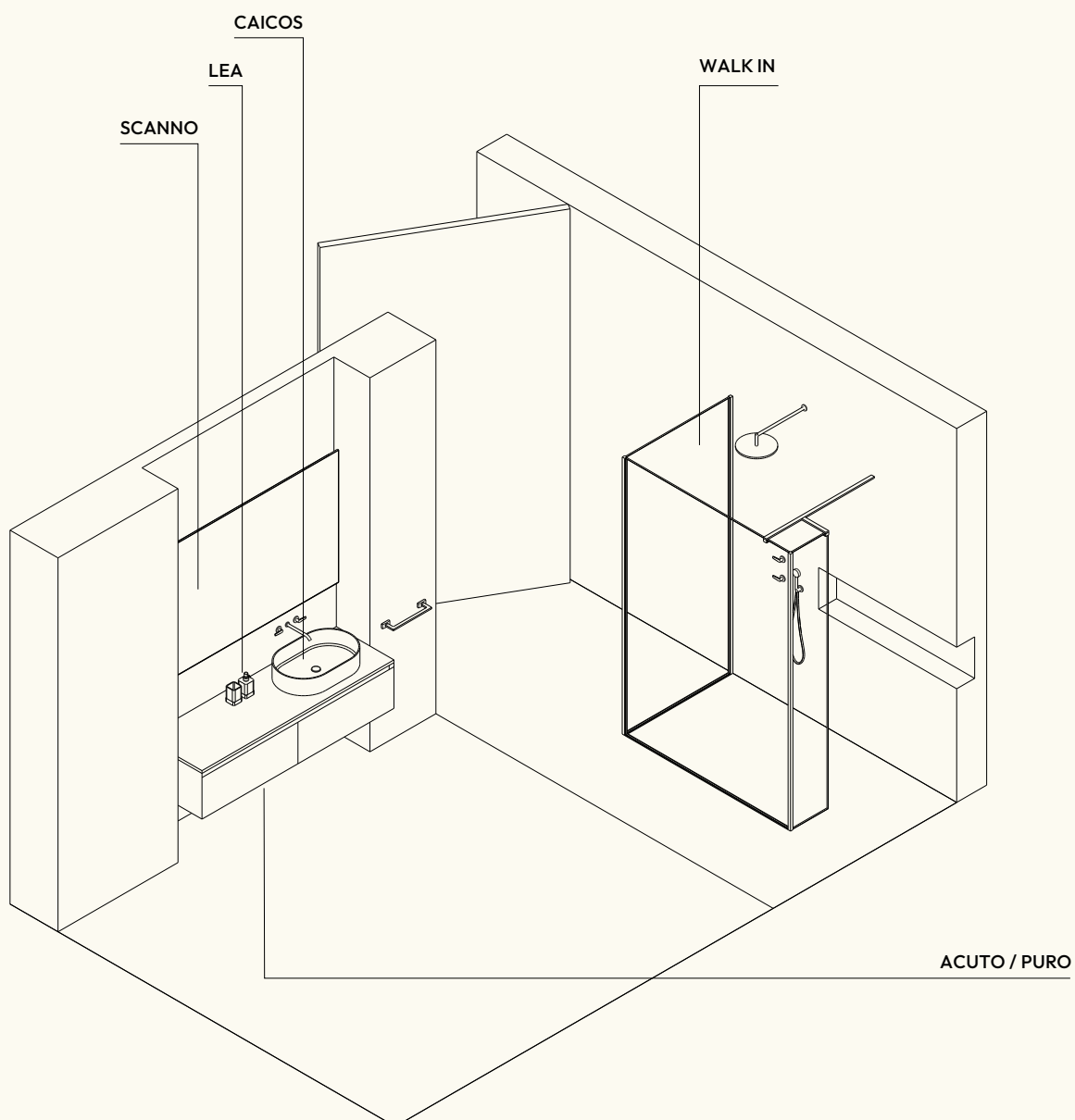









- IT **Frontali in decorativo Larice Cannella abbinati al lavabo da appoggio Caicos in solid surface, con top e alzatina in marmo Fior di Pesco. Accessori Lea in oro spazzolato.**
- EN Fronts in Larice Cannella decor finish paired with the Caicos countertop basin in Solid Surface, with top and backsplash in marble, Fior di Pesco finish. Lea accessories in brushed gold finish.
- DE Fronten im Dekor Larice Cannella, kombiniert mit dem Aufsatzbecken Caicos aus Solid Surface, mit Abdeckplatten und Spritzschutz aus Marmor in Fior-di-Pesco-Ausführung. Accessoires Lea in gebürsteter Goldausführung.
- FR Façades en décor Larice Cannella associées à la vasque à poser Caicos en Solid Surface, avec plan et crédence en marbre finition Fior di Pesco. Accessoires Lea en finition doré brossé.

- IT **La finitura oro spazzolato del profilo rafforza la continuità di Walk In, unendo precisione tecnica e valore estetico.**
- EN The brushed gold finish of the profile enhances the continuity of Walk In, combining technical precision and aesthetic value.
- DE Die Ausführung Gebürstetes Gold des Profils unterstreicht die Kontinuität der Walk In und vereint technische Präzision mit ästhetischem Anspruch.
- FR La finition doré brossé du profil renforce la continuité de Walk In, en associant précision technique et valeur esthétique.





# 01 ACUTO / PURO

## SCANNO

- IT Specchio d'arredo\_Metal Grey.  
EN Mirror\_Metal Grey.  
DE Spiegel\_Metal Grey.  
FR Miroir\_Metal Grey.

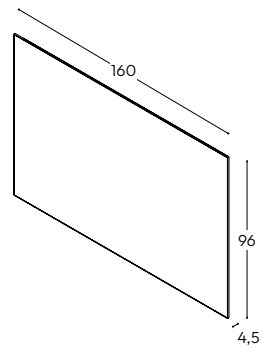

## LEA

- IT Accessori\_Oro Spazzolato / Vetro satinato.  
EN Accessories\_Brushed Gold / Satined Glass.  
DE Accessoires\_Gebürstetes Gold / Satiniertes Glas.  
FR Accessoires\_Doré Brossé / Verre satiné.

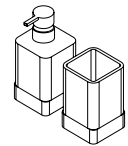

## CAICOS

- IT Lavabo da appoggio\_Bianco opaco, solid surface.  
EN Tabletop washbasin\_Matt white, solid surface.  
DE Aufsatzbecken\_Weiß matt, Solid Surface.  
FR Vasque à poser\_Blanc mat, solid surface.

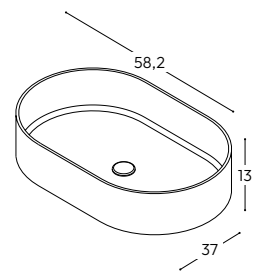

## ACUTO / PURO

- IT Frontali\_LARICE CANNELLA decorativo.  
Struttura\_LARICE CANNELLA decorativo.  
Top\_FIOR DI PESCO marmo lucido.  
Alzatina\_FIOR DI PESCO marmo lucido.  
EN Fronts\_LARICE CANNELLA decor.  
Structure\_LARICE CANNELLA decor.  
Worktop\_LARICE CANNELLA decor.  
Backsplash\_FIOR DI PESCO glossy marble  
DE Fronten\_LARICE CANNELLA Holzdekor.  
Möbelkorpus\_LARICE CANNELLA Holzdekor.  
Abdeckplatte\_LARICE CANNELLA Holzdekor.  
Passblende\_FIOR DI PESCO Marmor, glänzend  
FR Façades\_LARICE CANNELLA décor bois.  
Structure\_LARICE CANNELLA décor bois.  
Plan\_LARICE CANNELLA décor bois.  
Rehausse\_FIOR DI PESCO marbre brillant.

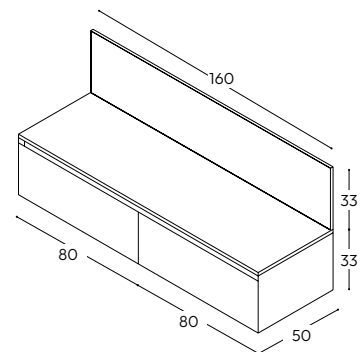

## pag. 013

## WALK IN

- IT Parete doccia\_Walk In: Oro spazzolato / Vetro Trasparente Bronzo (120x70xH200 cm).  
EN Shower enclosure\_Walk In: Brushed Gold / Transparent Bronze Glass (120x70xH200 cm).  
DE Duschabtrennung\_Walk In: Gebürstetes Gold / Bronze Klarglas (120x70xH200 cm).  
FR Parois de douche\_Walk In: Doré Brossé / Verre bronze transparent (120x70xH200 cm).

## FINITURE Finishing / Ausführungen / Finitions



LARICE CANNELLA

decorativo / decor /  
Holzdekor / décor bois



FIOR DI PESCO

marmo lucido / glossy marble /  
glänzender Marmor / marbre brillant



## 02 ACUTO / MIDI

IT UN EQUILIBRIO SOSPESO  
UNISCE LEGNO, MARMO E LACCATO  
IN UNA RELAZIONE MISURATA  
TRA FUNZIONE E DETTAGLIO.

EN A suspended balance brings together wood, marble and lacquer  
in a measured relationship between function and detail.

DE Ein schwebendes Gleichgewicht vereint Holz, Marmor und Lack in  
einer ausgewogenen Beziehung zwischen Funktion und Detail.

FR Un équilibre suspendu unit bois, marbre et laqué dans une relation  
mesurée entre fonction et détail.

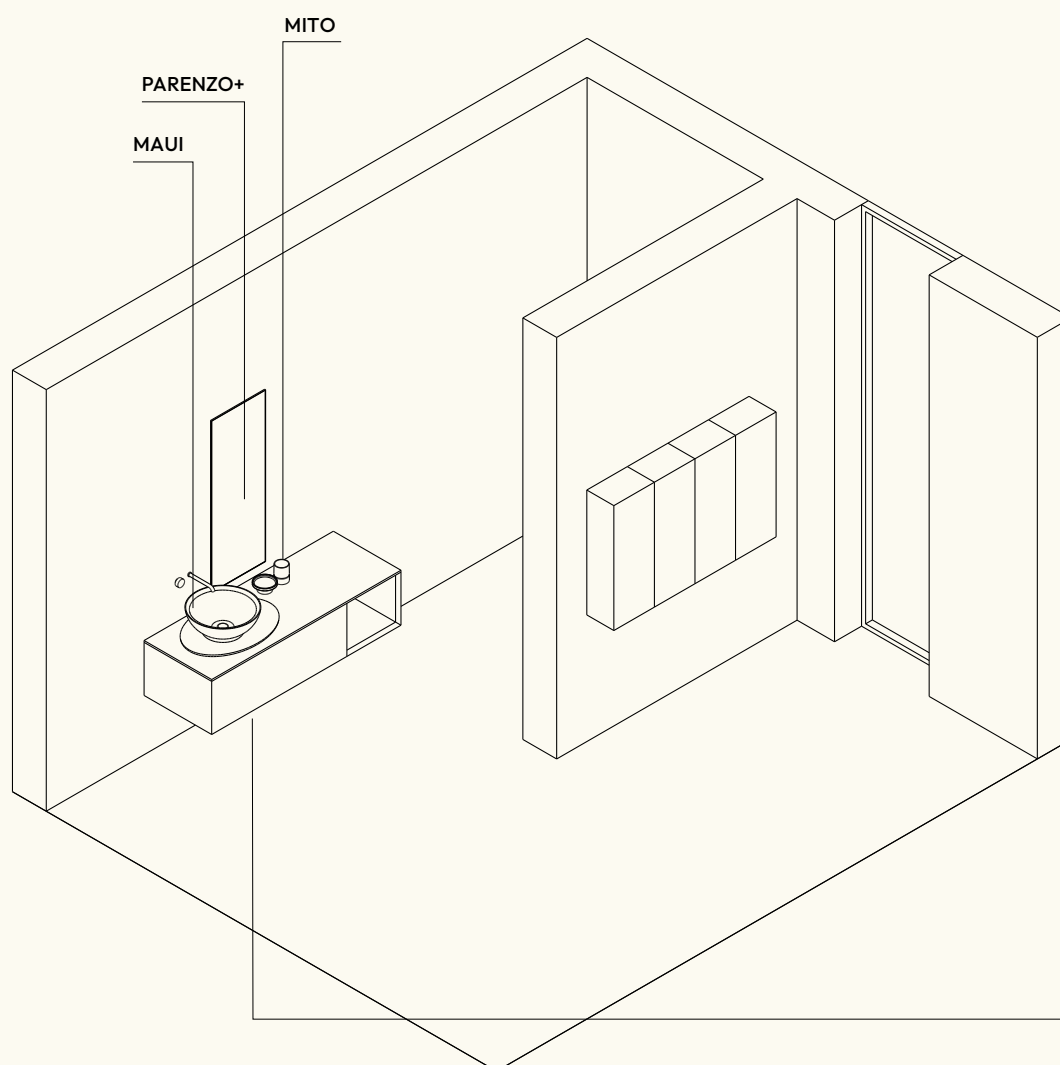







- IT **Frontali e top in decorativo Quercia Nature con lavabo d'appoggio in marmo scavato Maui con abbinato vassoio in finitura Breccia Capraia. Accessori Mito in nickel spazzolato.**
- EN Fronts and top in Quercia Nature decor finish with Maui countertop basin in carved marble, combined with tray in Breccia Capraia finish. Mito accessories in brushed nickel.
- DE Fronten und Abdeckplatten in Dekor Quercia Nature mit Aufsatzbecken Maui aus massivem Marmor, kombiniert mit passendem Tablett in Breccia Capraia Ausführung. Accessoires Mito aus gebürstetes nickel.
- FR Façades et plan en décor Quercia Nature avec vasque à poser Maui en marbre massif creusé, associée à un plateau en finition Breccia Capraia. Accessoires Mito en acier nickel brossé.





IT **Base con vano a giorno in laccato opaco Cuoio Bruciato; pensili in decorativo Quercia Nature.**

EN Base unit with open compartment in matt lacquer Cuoio Bruciato; wall units in Quercia Nature decor finish.

DE Unterschrank mit offenem Fach in matt lackiert Cuoio Bruciato; Hängeschränke in Dekor Quercia Nature.

FR Meuble bas avec niche ouverte en laqué mat Cuoio Bruciato; meubles hauts en décor Quercia Nature.





## 02 ACUTO / MIDI

### PARENZO+

- IT Specchio con illuminazione\_Nero opaco.  
EN Mirror with lighting\_Matt black.  
DE Lichtspiegel\_schwarz matt.  
FR Miroir avec éclairage\_Noir mat.

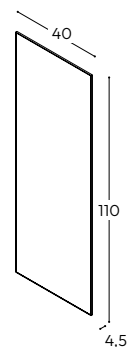

### MITO

- IT Accessori\_Nickel spazzolato / Vetro satinato.  
EN Accessories\_Brushed nickel / Satined Glass.  
DE Accessoires\_Gebürstetes Nickel / Satiniertes Glas.  
FR Accessoires\_Nickel brossé / Verre satiné.

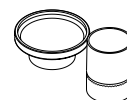

### MAUI

- IT Lavabo da appoggio con vassoio ovale\_BRECCIA CAPRAIA marmo lucido.  
EN Tabletop washbasin with oval tray\_BRECCIA CAPRAIA glossy marble.  
DE Aufsatzbecken und ovales Tablett\_BRECCIA CAPRAIA Marmor, glänzend.  
FR Vasque à poser et plateau ovale\_BRECCIA CAPRAIA marbre brillant.

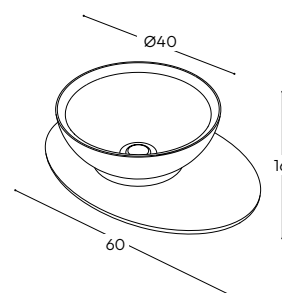

### ACUTO / MIDI

- IT Frontali\_QUERCIA NATURE decorativo.  
Struttura\_QUERCIA NATURE decorativo.  
Top\_QUERCIA NATURE decorativo.  
Vano a giorno\_CUOIO BRUCIATO laccato opaco.
- EN Fronts\_QUERCIA NATURE decor.  
Structure\_QUERCIA NATURE decor.  
Worktop\_QUERCIA NATURE decor.  
Open cupboard\_CUOIO BRUCIATO matt lacquer.
- DE Fronten\_QUERCIA NATURE Holzdekor.  
Möbelkorpus\_QUERCIA NATURE Holzdekor.  
Abdeckplatte\_QUERCIA NATURE Holzdekor.  
Offener Hängeschrank\_CUOIO BRUCIATO matt lackiert.
- FR Façades\_QUERCIA NATURE décor bois.  
Structure\_QUERCIA NATURE décor bois.  
Plan\_QUERCIA NATURE décor bois.  
Meuble ouvert\_CUOIO BRUCIATO laqué mat.

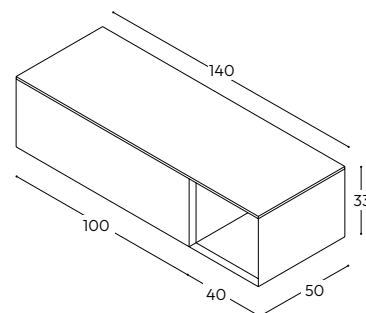

### pag. 023

- IT Pensili\_Frontali e Struttura: QUERCIA NATURE decorativo (30x21xH80 cm).  
EN Wall units\_Fronts and Structure: QUERCIA NATURE decor (30x21xH80 cm).  
DE Hängeschränke\_Fronten und Möbelkorpus: QUERCIA NATURE Holzdekor (30x21xH80 cm).  
FR Meuble hauts\_Façade et Structure: QUERCIA NATURE décor bois (30x21xH80 cm).

## FINITURE Finishing / Ausführungen / Finitions



QUERCIA NATURALE

decorativo / decor /  
Holzdekor / décor bois

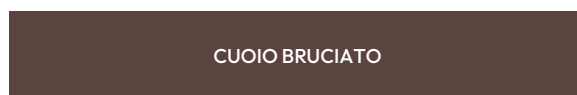

CUOIO BRUCIATO

laccato opaco / matt lacquered /  
matt lackiert / laqué mat



## 03 ACUTO / PURO

IT PROPORZIONI MISURATE  
E SUPERFICI DEFINITE DELINEANO  
UNA CONFIGURAZIONE IN CUI FUNZIONE  
ED ESTETICA SI ARMONIZZANO  
CON NATURALITÀ.

EN Measured proportions and defined surfaces outline a configuration in which function and aesthetics blend naturally.

DE Ausgewogene Proportionen und klar definierte Oberflächen zeichnen eine Konfiguration, in der sich Funktion und Ästhetik auf natürliche Weise vereinen.

FR Des proportions mesurées et des surfaces définies dessinent une configuration dans laquelle fonction et esthétique s'harmonisent naturellement.

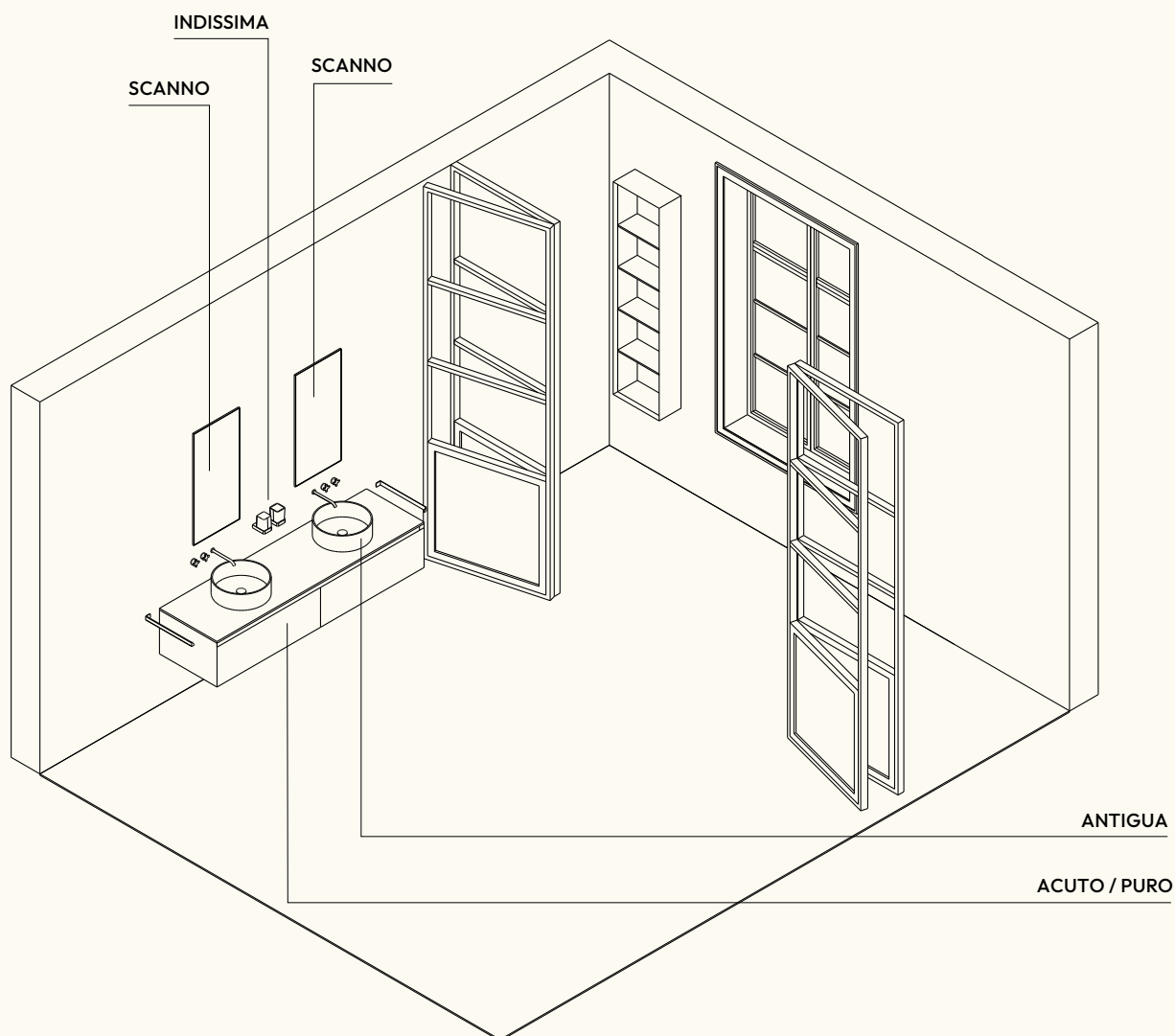









- IT **Frontali in laccato opaco Cuoio Bruciato con top in gres Calacatta Viola e lavabo d'appoggio Antigua in Solid Surface. Accessori Indissima Chrome in finitura oro spazzolato.**
- EN **Fronts in matt lacquer Cuoio Bruciato with top in gres Calacatta Viola and Antigua countertop basin in Solid Surface. Indissima Chrome accessories in brushed gold finish.**
- DE **Fronten in matt lackiertem Cuoio Bruciato mit Abdeckplatten aus Feinsteinzeug Calacatta Viola und Aufsatzbecken Antigua aus Solid Surface. Accessoires Indissima Chrome in gebürsteter Gold-Ausführung.**
- FR **Façades en laqué mat Cuoio Bruciato avec plan en gres Calacatta Viola et vasque à poser Antigua en Solid Surface. Accessoires Indissima Chrome en finition doré brossé.**

- IT **La finitura laccato opaco Cuoio Bruciato valorizza i vani a giorno, rendendoli un elemento distintivo dal marcato impatto cromatico.**
- EN The matt lacquer Cuoio Bruciato finish enhances the open compartments, making them a distinctive element with a strong chromatic impact.
- DE Die matt lackierte Ausführung Cuoio Bruciato betont die offenen Fächer und macht sie zu einem prägenden Element mit starker farblicher Wirkung.
- FR La finition laqué mat Cuoio Bruciato valorise les niches ouvertes, en les rendant un élément distinctif à fort impact chromatique.





## 03 ACUTO / PURO

### SCANNO

- IT Specchio d'arredo\_Metal grey.  
EN Mirror\_Metal grey.  
DE Spiegel\_Metal grey.  
FR Miroir\_Metal grey.

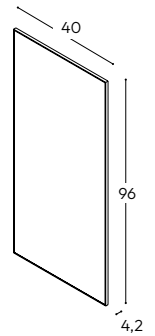

### INDISSIMA CHROME

- IT Accessori\_Oro spazzolato / Vetro satinato.  
EN Accessories\_Brushed Gold / Satined Glass.  
DE Accessoires\_Gebürstetes Gold / Satiniertes Glas.  
FR Accessoires\_Doré Brossé / Verre satiné.

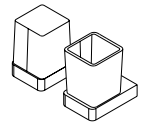

### ANTIGUA

- IT Lavabo da appoggio\_Bianco opaco, solid surface.  
EN Tabletop washbasin\_Matt white, solid surface.  
DE Aufsatzbecken\_Weiß matt, solid surface.  
FR Vasque à poser\_Blanc mat, solid surface.

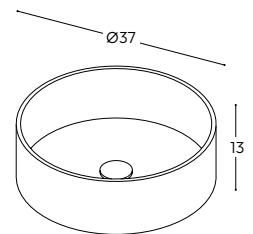

### ACUTO / PURO

- IT Frontali\_CUOIO BRUCIATO laccato opaco.  
Struttura\_CUOIO BRUCIATO laccato opaco.  
Top\_CALACATTA VIOLA, gres lucido.  
EN Fronts\_CUOIO BRUCIATO matt lacquer.  
Structure\_CUOIO BRUCIATO matt lacquer.  
Worktop\_CALACATTA VIOLA, glossy gres.  
DE Fronten\_CUOIO BRUCIATO matt lackiert.  
Möbelkorpus\_CUOIO BRUCIATO matt lackiert.  
Abdeckplatte\_CALACATTA VIOLA, Feinsteinzeug glänzend.  
FR Façades\_CUOIO BRUCIATO laqué mat.  
Structure\_CUOIO BRUCIATO laqué mat.  
Plan\_CALACATTA VIOLA, gres brillant.

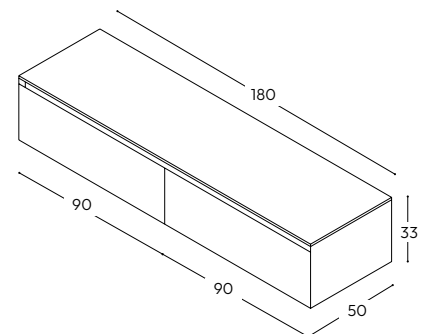

### pag. 033

- IT Vani a giorno\_Structura: CUOIO BRUCIATO laccato opaco (42x21xH160 cm).  
EN Open compartments\_Structure: CUOIO BRUCIATO matt lacquer (42x21xH160 cm).  
DE Offene Fächer\_Möbelkorpus: CUOIO BRUCIATO matt lackiert (42x21xH160 cm).  
FR Compartiments ouverts\_Structure: CUOIO BRUCIATO laqué mat (42x21xH160 cm).

## FINITURE Finishing / Ausführungen / Finitions

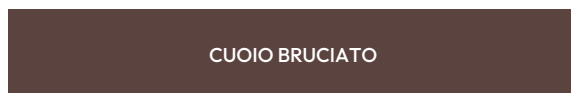

CUOIO BRUCIATO

laccato opaco / matt lacquered /  
matt lackiert / laqué mat



CALACATTA VIOLA

gres lucido / glossy gres /  
Feinsteinzeug glänzende / grès brillant



## 04 ACUTO / PURO

IT UN COMODO VANO A GIORNO E DUE  
CAPIENTI CASSETTONI AFFIANCATI:  
COME CONTENERE – CON STILE – TUTTI  
GLI OGGETTI DI USO QUOTIDIANO.

EN A practical open compartment and two spacious side-by-side drawers:  
how to store – in style – all everyday items.

DE Ein praktisches offenes Fach und zwei geräumige nebeneinander  
angeordnete Schubladen: wie man – stilvoll – alle Gegenstände des  
täglichen Gebrauchs verstau

FR Une niche ouverte pratique et deux grands tiroirs côte à côte: comment  
ranger – avec style – tous les objets du quotidien.

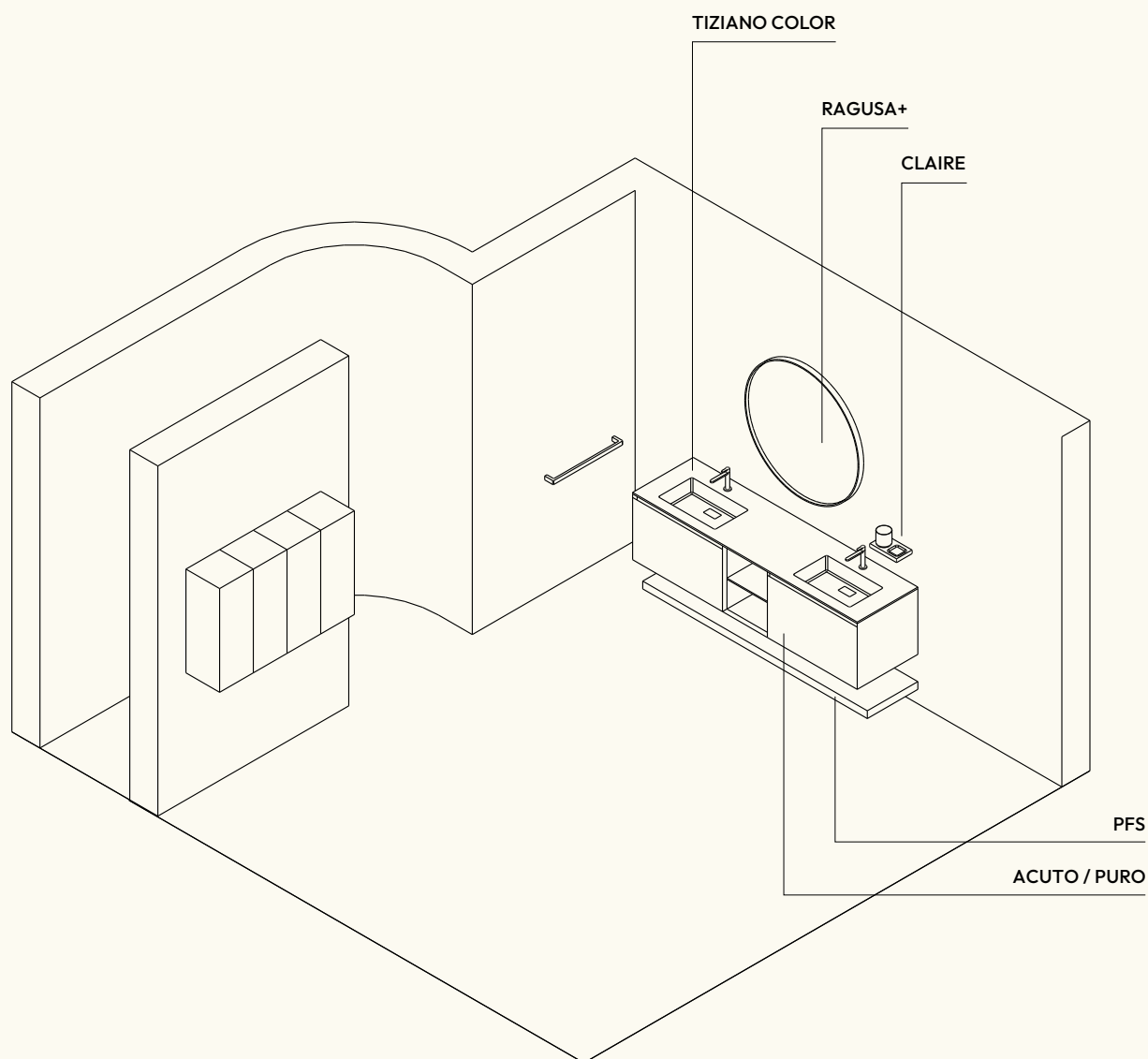







- IT **Frontali in legno Rovere Cenere impiallacciato con lavabo Tiziano Color in mineralguss, tonalità Avorio. Mensola in legno impiallacciato coordinato. Accessori Claire in nero opaco.**
- EN **Fronts in veneered Rovere Cenere wood with Tiziano Color basin in mineralguss, Avorio shade. Coordinated veneered wood shelf. Claire accessories in matt black.**
- DE **Fronten in furniertem Rovere Cenere mit Becken Tiziano Color aus Mineralguss, Farbton Avorio. Abgestimmtes Regal aus furniertem Holz. Accessoires Claire in matt Schwarz.**
- FR **Façades en bois plaqué Rovere Cenere avec vasque Tiziano Color en marbre de synthèse, teinte Avorio. Étagère coordonnée en bois plaqué. Accessoires Claire en noir mat.**



- IT **Set di pensili in laccato opaco Avorio, con tre ripiani che organizzano l'ordine e la funzionalità dello spazio contenitivo.**
- EN Set of wall units in matt lacquer Avorio, with three shelves that organize the order and functionality of the storage space.
- DE Set aus Hängeschränken in matt lackiert Avorio, mit drei Einlegeböden, die Ordnung und Funktionalität des Stauraums strukturieren.
- FR Ensemble de meubles hauts en laqué mat Avorio, avec trois étagères qui organisent l'ordre et la fonctionnalité de l'espace de rangement.





## 04 ACUTO / PURO

### RAGUSA+

- IT Specchio con illuminazione\_Nero opaco.  
 EN Mirror with lighting\_Matt black.  
 DE Lichtspiegel\_schwarz matt.  
 FR Miroir avec éclairage\_Noir mat.

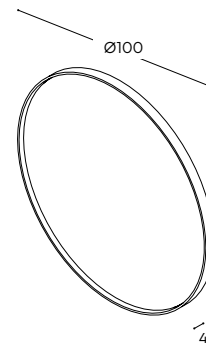

### CLAIRE

- IT Accessorio\_Nero opaco / Vetro mono satinato fumè.  
 EN Accessorie\_Matt black / Smoked single satin glass.  
 DE Accessoire\_Schwarz matt / Rauchglas, einseitig satiniert.  
 FR Accessoire\_Noir mat / Verre fumé satiné simple face.

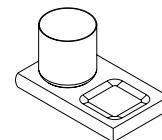

### TIZIANO COLOR

- IT Lavabo integrato\_AVORIO, mineralguss.  
 EN Integrated washbasin\_AVORIO, mineral marble.  
 DE Integriertes Waschbecken\_AVORIO, Mineralguss.  
 FR Vasque intégrée\_AVORIO, marbre de synthèse.

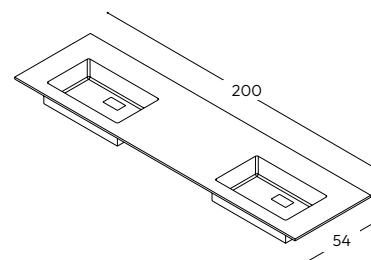

### ACUTO / DUAL

- IT Frontali\_ROVERE CENERE legno impiallacciato.  
 Struttura\_ROVERE CENERE legno impiallacciato.  
 Vani a giorno\_ROVERE CENERE legno impiallacciato.  
 PFS\_ROVERE CENERE legno impiallacciato.  
 EN Fronts\_ROVERE CENERE wood veneer.  
 Structure\_ROVERE CENERE wood veneer.  
 Open compartments\_ROVERE CENERE wood veneer.  
 PFS\_ROVERE CENERE wood veneer.  
 DE Front\_ROVERE CENERE Furnierholz.  
 Möbelkorpus\_ROVERE CENERE Furnierholz.  
 Offene Fächer\_ROVERE CENERE Furnierholz.  
 PFS\_ROVERE CENERE Furnierholz.  
 FR Façades\_ROVERE CENERE bois plaqué.  
 Structure\_ROVERE CENERE bois plaqué.  
 Compartiments ouverts\_ROVERE CENERE bois plaqué.  
 PFS\_ROVERE CENERE bois plaqué.

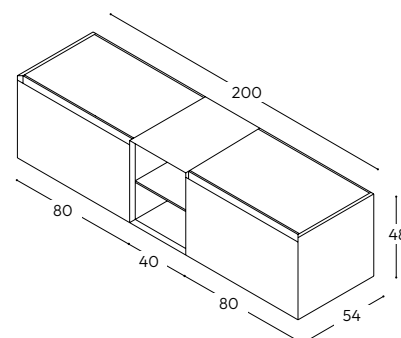

### pag. 043

- IT Pensili\_Frontali e Struttura: ROVERE CENERE legno impiallacciato (30x30xH80 cm).  
 EN Wall units\_Fronts and Structure: ROVERE CENERE wood veneer (30x30xH80 cm).  
 DE Hängeschränke\_Fronten und Möbelkorpus: ROVERE CENERE Furnierholz (30x30xH80 cm).  
 FR Meuble hauts\_Façade et Structure: ROVERE CENERE bois plaqué (30x30xH80 cm).

## FINITURE Finishing / Ausführungen / Finitions



ROVERE CENERE

legno impiallacciato / wood veneer /  
 Furnierholz / bois plaqué



AVORIO

laccato opaco / matt lacquered /  
 matt lackiert / laqué mat



## 05 ACUTO / MIDI

IT VOLUMI PIENI E SUPERFICI NETTE  
DEFINISCONO L'AMBIENTE, MENTRE  
IL COLORE NE STRUTTURA L'EQUILIBRIO  
E NE RAFFORZA LA PRESENZA SCENICA.

EN Solid volumes and clean surfaces define the space, while color structures  
its balance and enhances its visual presence.

DE Volle Volumen und klare Oberflächen definieren den Raum, während  
die Farbe sein Gleichgewicht strukturiert und seine szenische Präsenz  
verstärkt.

FR Des volumes pleins et des surfaces nettes définissent l'espace, tandis que  
la couleur en structure l'équilibre et en renforce la présence scénique.

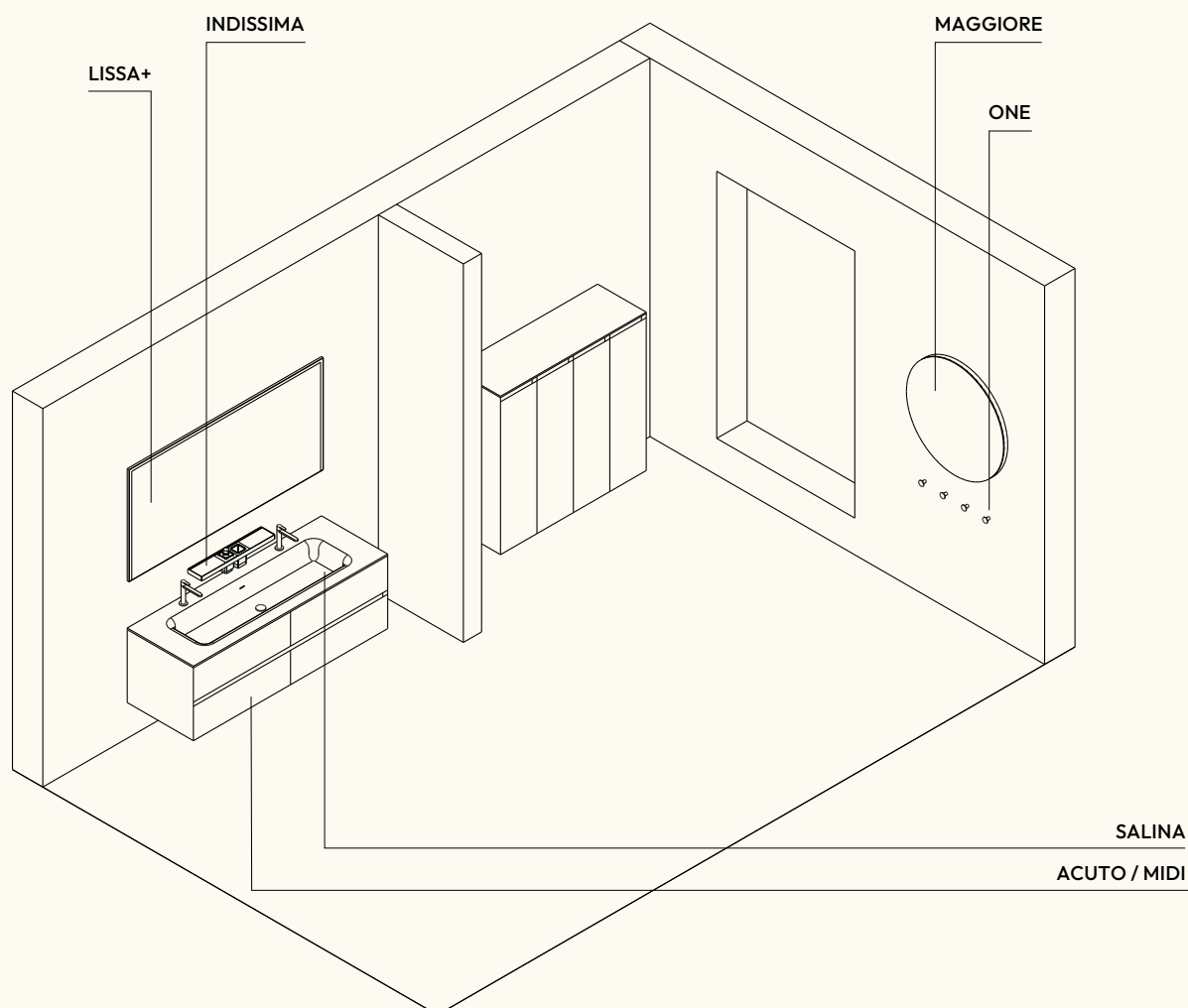





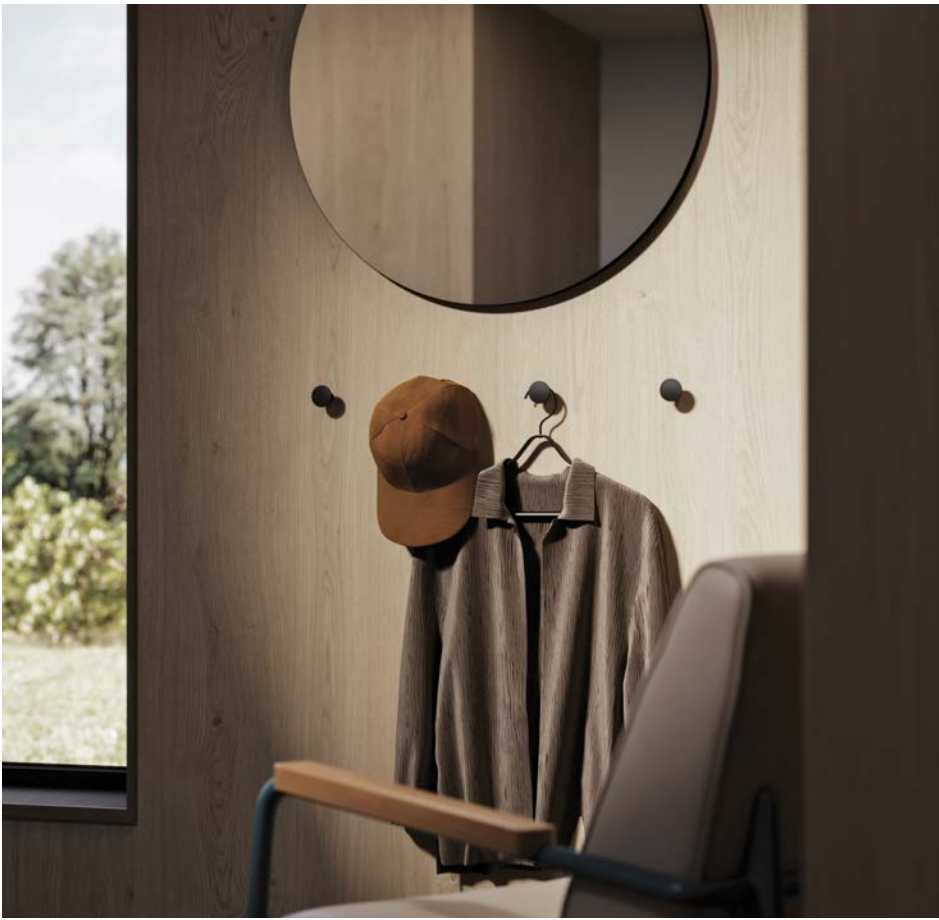

- IT **Frontali in laccato lucido Cemento con lavabo integrato Salina in mineralguss. Barra modulare Indissima in finitura nero opaco. Specchio Lissa+ in finitura nero opaco.**
- EN **Fronts in glossy lacquer Cemento with integrated Salina basin in mineralguss. Indissima modular bar in matt black finish. Lissa+ mirror in matt black finish.**
- DE **Fronten in hochglänzend lackiert Cemento mit integriertem Becken Salina aus Mineralguss. Modulare Stange Indissima in matt Schwarz Ausführung. Spiegel Lissa+ in matt Schwarz Ausführung.**
- FR **Façades en laqué brillant Cemento avec vasque intégrée Salina en marbre de synthèse. Barre modulaire Indissima en finition noir mat. Miroir Lissa+ en finition noir mat.**



- IT **Colonne sospese in laccato opaco Avio con tre ripiani interni, progettate per scandire lo spazio con misura e continuità.**
- EN Wall-mounted tall units in matt lacquer Avio with three internal shelves, designed to articulate the space with balance and continuity.
- DE Hängende Hochschränke in matt lackiert Avio mit drei Innenböden, konzipiert, um den Raum mit Maß und Kontinuität zu gliedern.
- FR Colonne suspendues en laqué mat Avio avec trois étagères intérieures, conçues pour rythmer l'espace avec mesure et continuité.





## **05 ACUTO** / MIDI

### **LISSA+**

- IT Specchio con illuminazione\_Nero opaco.  
EN Mirror with lighting\_Matt black.  
DE Lichtspiegel\_Schwarz matt.  
FR Miroir avec éclairage\_Noir mat.

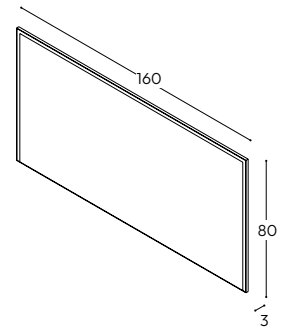

### **INDISSIMA**

- IT Accessori\_Nero opaco / Vetro satinato.  
EN Accessories\_Matt black / Satined Glass.  
DE Accessoires\_Schwarz matt / Satiniertes Glas.  
FR Accessoires\_Noir mat / Verre satiné.

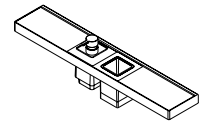

### **SALINA**

- IT Lavabo integrato\_Bianco opaco, mineralguss.  
EN Integrated washbasin\_Matt white, mineral marble.  
DE Integriertes Waschbecken\_Weiß matt, Mineralguss.  
FR Vasque intégrée\_Blanc mat, marbre de synthèse.

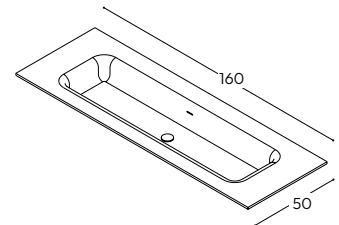

### **ACUTO / MIDI**

- IT Frontali\_CEMENTO laccato lucido.  
Struttura\_CEMENTO laccato lucido.  
EN Fronts\_CEMENTO glossy lacquer.  
Structure\_CEMENTO glossy lacquer.  
DE Fronten\_CEMENTO glänzend lackiert.  
Möbelkorpus\_CEMENTO glänzend lackiert.  
FR Façades\_CEMENTO laqué brillant.  
Structure\_CEMENTO laqué brillant.

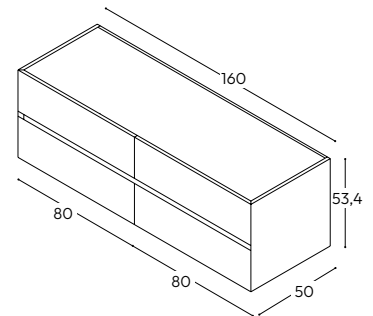

### **pag. 053**

- IT Colonne\_Frontali, Struttura e Top: AVIO laccato opaco (30x40xH112 cm).  
EN Columns\_Fronts, Structure and Worktop: AVIO matt lacquer (30x40xH112 cm).  
DE Hochschränke\_Fronten, Möbelkorpus und Abdeckplatte: AVIO matt lackiert (30x40xH112 cm).  
FR Colonnes\_Façade, Structure et Plan: AVIO laqué mat (30x40xH112 cm).

## **FINITURE** Finishing / Ausführungen / Finitions

### **CEMENTO**

laccato lucido / glossy lacquer /  
glänzend lackiert / laqué brillant



## 06 ACUTO / PURO / PURO

IT COMPOSIZIONE GEMELLA, VALORIZZATA DA MATERIALI PREGIATI, ORGANIZZA LO SPAZIO CON BILANCIAMENTO FORMALE E MISURA SENZA TEMPO.

EN Twin composition, enhanced by fine materials, organizes the space with formal balance and timeless restraint.

DE Zwillingskomposition, durch hochwertige Materialien aufgewertet, organisiert den Raum mit formaler Ausgewogenheit und zeitloser Maßhaltung.

FR Composition jumelle, valorisée par des matériaux précieux, organise l'espace avec équilibre formel et mesure intemporelle.

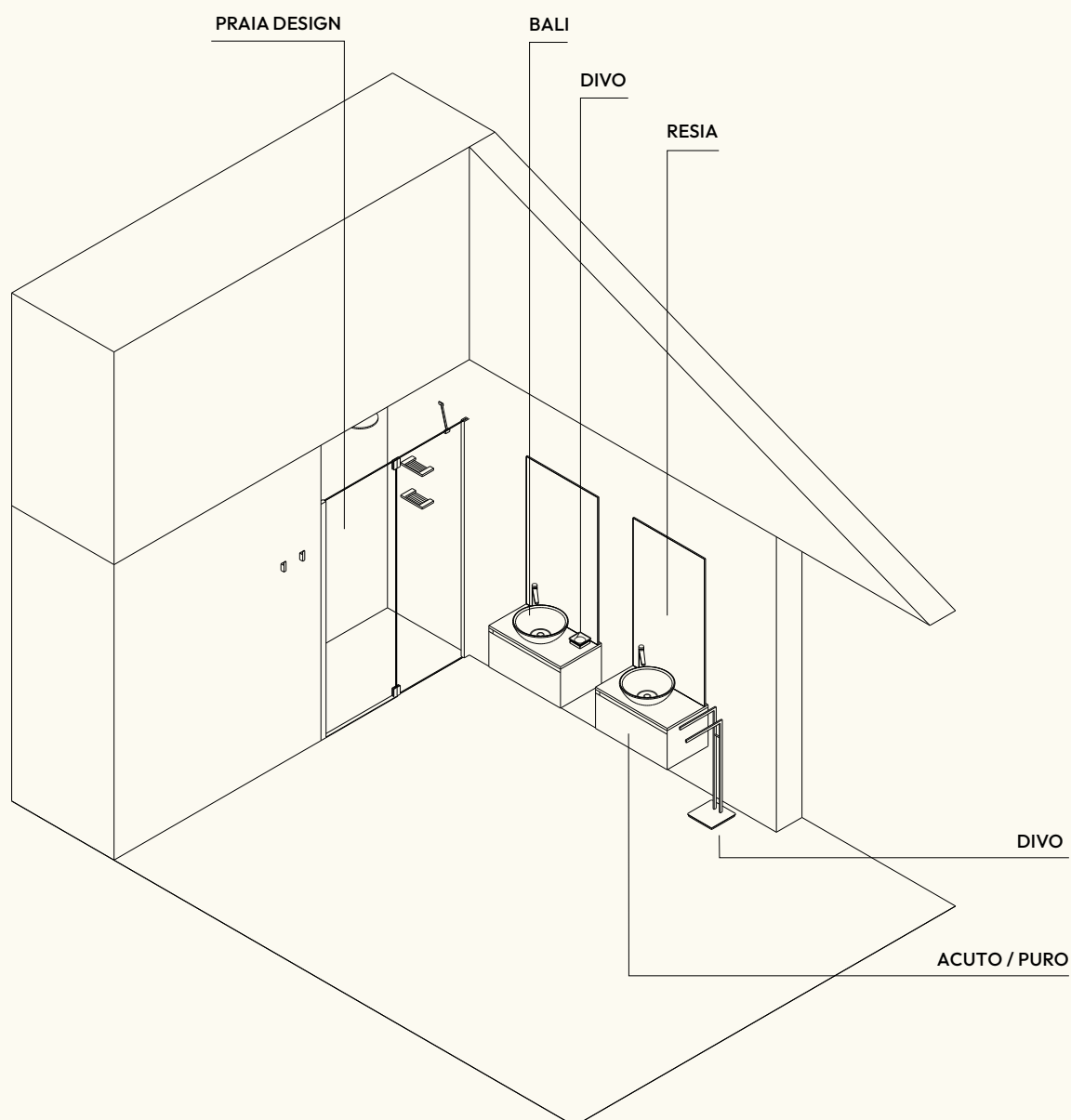







- IT **Frontali in legno Rovere Cenere impiallacciato con lavabo scavato Bali e top entrambi in marmo lucido Bianco Dolomite. Accessorio e piantana Divo in nero opaco.**
- EN Fronts in veneered Rovere Cenere wood with Bali carved basin and top, both in polished Bianco Dolomite marble. Divo accessory and floor stand in matt black.
- DE Fronten in furniertem Rovere Cenere mit ausgehöhltem Becken Bali und Abdeckplatten, beide aus poliertem Marmor Bianco Dolomite. Accessoire und Standfuß Divo in matt Schwarz.
- FR Façades en bois plaqué Rovere Cenere avec vasque creusée Bali et plan, tous deux en marbre poli Bianco Dolomite. Accessoire et pied Divo en noir mat.



- IT **Praia Design con maniglia integrata a tutta altezza, definita da un profilo pulito in finitura nero opaco. Accessori Divo coordinati.**
- EN Praia Design with a full-height integrated handle, defined by a clean profile in matte black finish. Coordinated Divo accessories.
- DE Praia Design mit durchgehender, integrierter Griffleiste, geprägt von einer klaren Kontur in mattschwarzer Ausführung. Passende Divo-Accessoires.
- FR Praia Design avec poignée intégrée sur toute la hauteur, définie par un profil épuré en finition noir mat. Accessoires Divo coordonnés.



A light-colored, textured bathrobe hangs on a black hook against the vertical wood slat wall.

A glass shower enclosure with black frames is set against a wall with a textured grey finish. The enclosure includes a black showerhead, a handheld shower wand, and two black shelves holding bottles of shampoo and conditioner.

A floating vanity with a white, textured sink is mounted on a wall with a textured grey finish. The vanity has a dark wood-grain finish. A large mirror is mounted above the vanity, reflecting the shower area.

A brown, textured rug is placed on the floor in the foreground.



## **06 ACUTO** / PURO

### RESIA

- IT Specchio d'arredo.  
EN Mirror.  
DE Spiegel.  
FR Miroir.

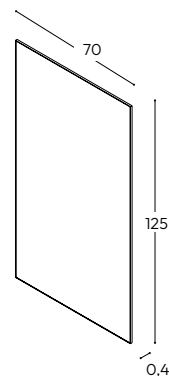

### DIVO

- IT Accessori\_Nero opaco / Vetro Trasparente.  
EN Accessories\_Matt black / Transparent Glass.  
DE Accessoires\_Schwarz matt / Transparentes Glas.  
FR Accessoires\_Noir mat / Verre Transparent.



### BALI

- IT Lavabo da appoggio\_BIANCO DOLOMITE marmo opaco.  
EN Tabletop washbasin\_BIANCO DOLOMITE matt marble.  
DE Aufsatzbecken\_BIANCO DOLOMITE, matter Marmor.  
FR Vasque à poser\_BIANCO DOLOMITE marbre mat.

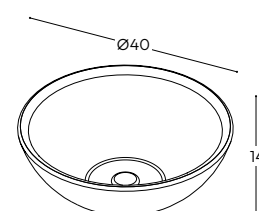

### ACUTO / PURO

- IT Frontali\_ROVERE CENERE legno impiallacciato.  
Struttura\_ROVERE CENERE legno impiallacciato.  
Top\_BIANCO DOLOMITE marmo opaco.  
EN Fronts\_ROVERE CENERE wood veneer.  
Structure\_ROVERE CENERE wood veneer.  
Worktop\_BIANCO DOLOMITE matt marble.  
DE Front\_ROVERE CENERE Furnierholz.  
Möbelkorpus\_ROVERE CENERE Furnierholz.  
Abdeckplatte\_BIANCO DOLOMITE, matter Marmor.  
FR Façades\_ROVERE CENERE bois plaqué.  
Structure\_ROVERE CENERE bois plaqué.  
Plan\_BIANCO DOLOMITE marbre mat.

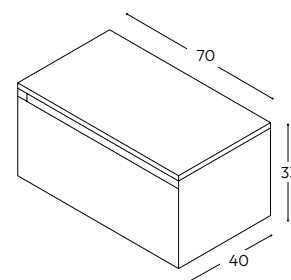

### pag. 063

### PRAIA DESIGN

- IT Parete doccia\_Porta battente con elemento fisso per nicchia: Nero opaco / Vetro Trasparente (140x90xH200 cm).  
EN Shower enclosure\_Hinged door with in-line fixed panel for recess: Matt black / Transparent Glass (140x90xH200 cm).  
DE Duschabtrennung\_Drehflügeltür mit feststehendem Element für Nische: Matt zwart / Klarglas (140x90xH200 cm).  
FR Paroi de douche\_Porte battante avec élément fixe en ligne pour niche: Noir mat / Verre Transparent (140x90xH200 cm).

## FINITURE Finishing / Ausführungen / Finitions



ROVERE CENERE

legno impiallacciato / wood veneer /  
Furnierholz / bois plaqué

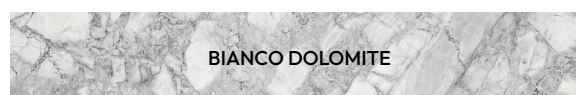

BIANCO DOLOMITE

marmo opaco / matt marble /  
matter Marmor / marbre mat



## 07 ACUTO / PURO

IT CROMIE CALDE E DETTAGLI SARTORIALI  
ARTICOLANO UN INSIEME MISURATO,  
DEFINITO DA VOLUMI COMPATTI  
E RIGOROSA COERENZA FORMALE.

EN Warm tones and tailored details articulate a measured ensemble, defined by compact volumes and rigorous formal coherence.

DE Warme Farbtöne und maßgeschneiderte Details prägen ein ausgewogenes Gesamtbild, das durch kompakte Volumen und strenge formale Kohärenz definiert ist.

FR Des tonalités chaudes et des détails sur mesure articulent un ensemble mesuré, défini par des volumes compacts et une rigoureuse cohérence formelle.

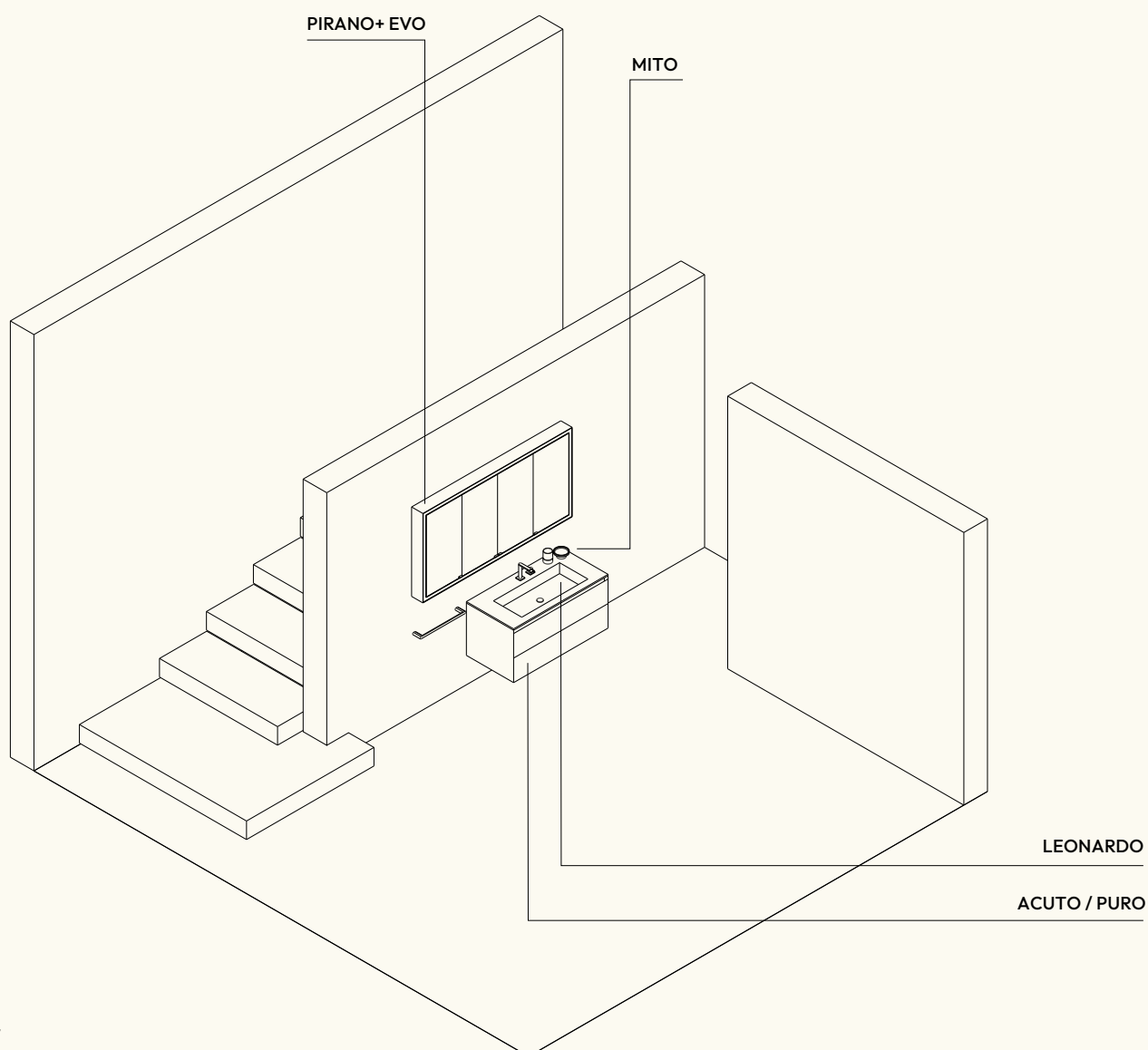





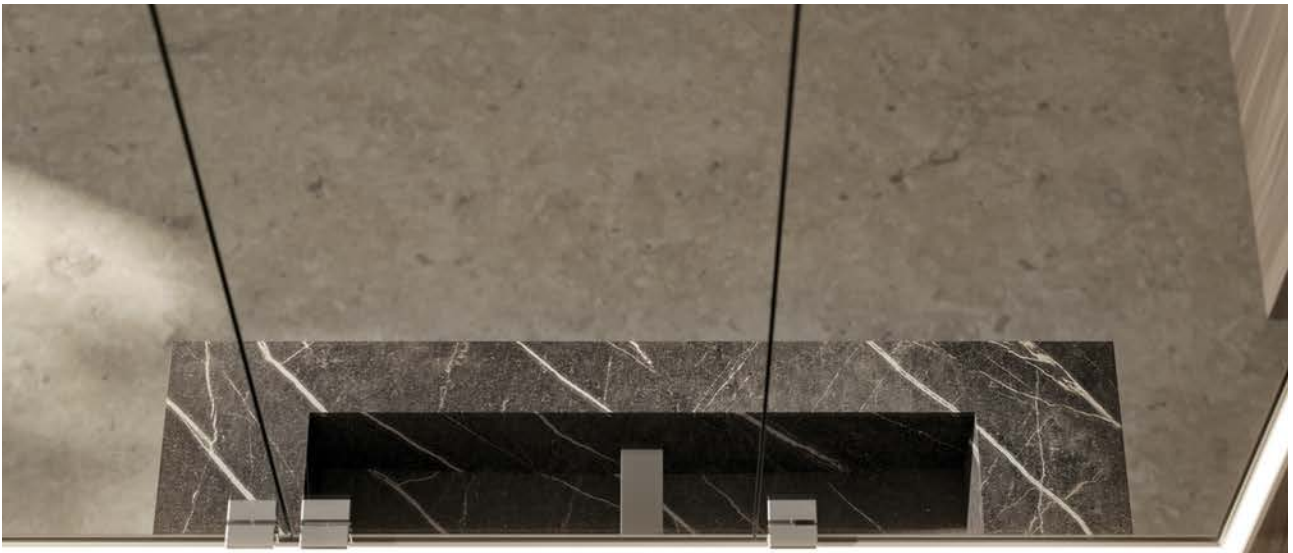

- IT **Frontali e struttura in laccato opaco Terracotta con lavabo integrato Leonardo in HPL Grigio Venato. Accessori Mito in finitura cromo.**
- EN Fronts and structure in matt lacquer Terracotta with integrated Leonardo basin in HPL Grigio Venato. Mito accessories in chrome finish.
- DE Fronten und Korpus in matt lackiert Terracotta mit integriertem Becken Leonardo aus HPL Grigio Venato. Mito-Accessoires in verchromter Ausführung.
- FR Façades et structure en laqué mat Terracotta avec vasque intégrée Leonardo en HPL Grigio Venato. Accessoires Mito en finition chromée.





- IT **Dettaglio dei comodi divisori per cassetto in metallo, finitura antracite.**  
Specchio Pirano+ Evo nella versione incasso a quattro ante, dotato di tre ripiani regolabili e illuminazione sui quattro lati.
- EN Detail of the practical metal drawer dividers in anthracite finish.  
Pirano+ Evo mirror in the four-door recessed version, equipped with three adjustable shelves and lighting on all four sides.
- DE Detail der praktischen Schubladeneinteiler aus Metall in Anthrazit Ausführung. Spiegel Pirano+ Evo in der viertürigen Einbauversion, ausgestattet mit drei verstellbaren Einlegeböden und Beleuchtung an allen vier Seiten.
- FR Détail des séparateurs de tiroir pratiques en métal, finition anthracite.  
Miroir Pirano+ Evo en version encastrée à quatre portes, doté de trois étagères réglables et d'un éclairage sur les quatre côtés.





## 07 ACUTO / PURO

### PIRANO+ EVO

- IT Specchio contenitore da incasso\_Metal grey.  
EN Built-in mirror cabinet\_Metal grey.  
DE Spiegelschrank für Wandeinbau\_Metal grey.  
FR Armoire de toilette à encastrer\_Metal grey.

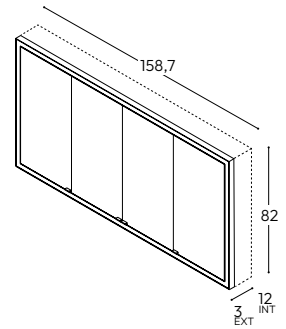

### MITO

- IT Accessori\_Cromato / Vetro satinato.  
EN Accessories\_Chrome / Satined Glass.  
DE Accessoires\_Verchromt / Satiniertes Glas.  
FR Accessoires\_Chromé / Verre satiné.



### LEONARDO

- IT Lavabo integrato\_GRIGIO VENATO HPL.  
EN Integrated washbasin\_GRIGIO VENATO HPL.  
DE Integriertes Waschbecken\_GRIGIO VENATO-HPL.  
FR Vasque intégrée\_HPL GRIGIO VENATO.

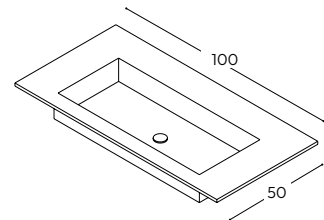

### ACUTO / PURO

- IT Frontali\_TERRACOTTA laccato opaco.  
Struttura\_TERRACOTTA laccato opaco.  
EN Fronts\_TERRACOTTA matt lacquer.  
Structure\_TERRACOTTA matt lacquer.  
DE Fronten\_TERRACOTTA matt lackiert.  
Möbelkorpus\_TERRACOTTA matt lackiert.  
FR Façades\_TERRACOTTA laqué mat.  
Structure\_TERRACOTTA laqué mat.

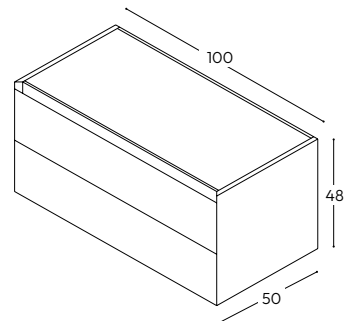

## FINITURE Finishing / Ausführungen / Finitions

TERRACOTTA

laccato opaco / matt lacquered /  
matt lackiert / laqué mat

GRIGIO VENATO

HPL



## 08 ACUTO / PURO

IT LINEE ESSENZIALI E SUPERFICI CONTINUE COSTRUISCONO UN'ATMOSFERA DI RAFFINATA LEGGEREZZA.

EN Essential lines and continuous surfaces create an atmosphere of refined lightness.

DE Essenzielle Linien und durchgehende Oberflächen schaffen eine Atmosphäre von raffinierter Leichtigkeit.

FR Des lignes essentielles et des surfaces continues créent une atmosphère de légèreté raffinée.

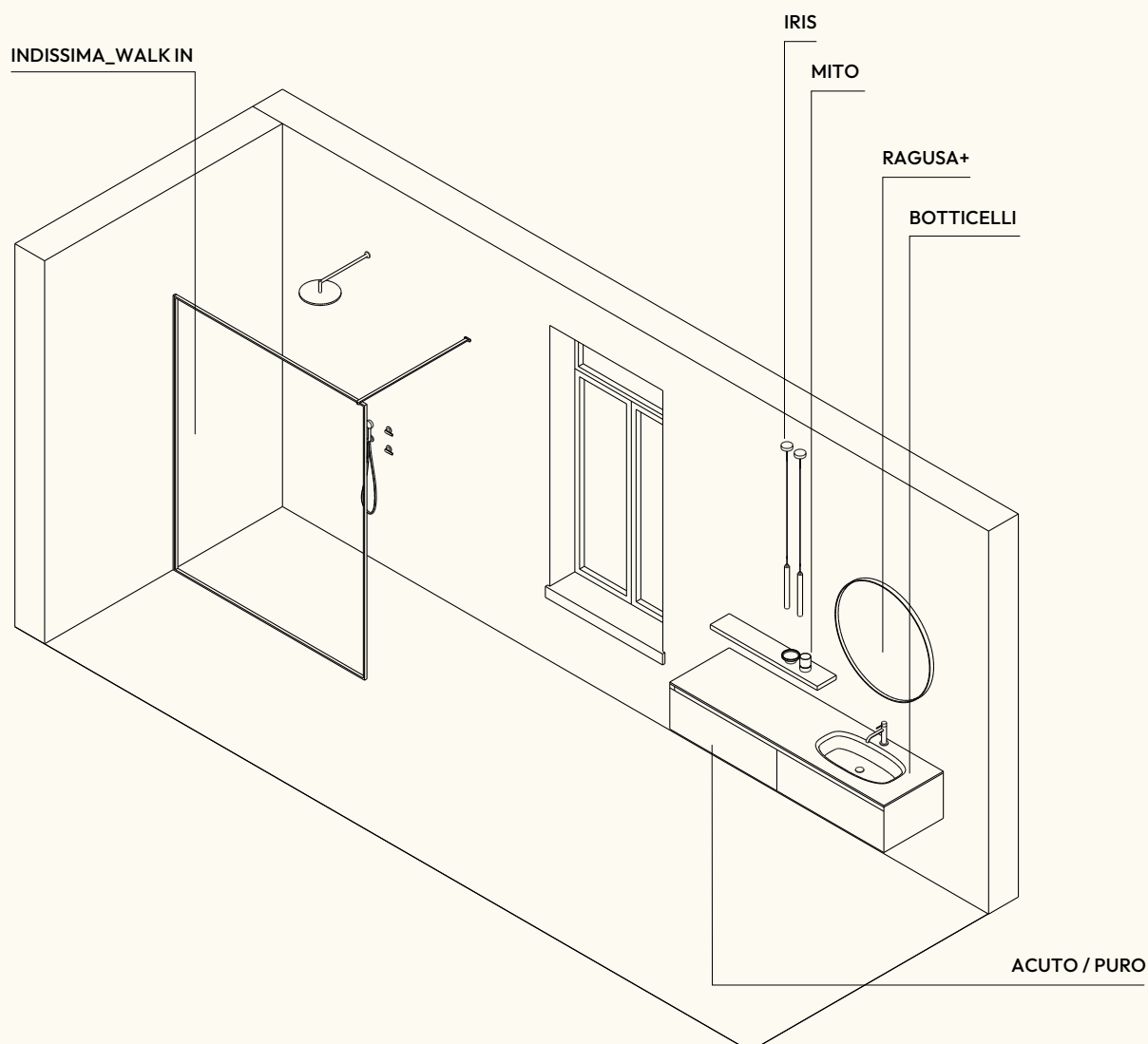









- IT** Frontali e mobile in laccato opaco Terra di Luna con piano con lavabo integrato Botticelli in Solid Surface, completati dagli accessori Mito e dallo specchio Ragusa+ in finitura nero opaco, in abbinamento alle lampade Calla nella stessa finitura.
- EN** Fronts and unit in matt lacquer Terra di Luna with countertop featuring integrated Botticelli basin in Solid Surface, completed by Mito accessories and the Ragusa+ mirror in matt black finish, paired with Calla lamps in the same finish.
- DE** Fronten und Möbel in matt lackiert Terra di Luna mit Abdeckplatten mit integriertem Becken Botticelli aus Solid Surface, ergänzt durch Accessoires Mito und den Spiegel Ragusa+ in matt Schwarz Ausführung, kombiniert mit Calla Leuchten in derselben Ausführung.
- FR** Façades et meuble en laqué mat Terra di Luna avec plan avec vasque intégrée Botticelli en Solid Surface, complétés par les accessoires Mito et le miroir Ragusa+ en finition noir mat, assortis aux lampes Calla dans la même finition.



- IT **Indissima\_Walk In, esprime uno stile essenziale, valorizzato dal nuovo vetro canettato che arricchisce l'estetica con un raffinato gioco di luce e trasparenze.**
- EN Indissima Walk In expresses an essential style, enhanced by the new fluted glass that enriches the aesthetics with a refined interplay of light and transparency.
- DE Indissima Walk In verkörpert einen essenziellen Stil, aufgewertet durch das neue geriffelte Glas, das die Ästhetik mit einem raffinierten Spiel aus Licht und Transparenz bereichert.
- FR Indissima Walk In exprime un style essentiel, valorisé par le nouveau verre cannelé qui enrichit l'esthétique d'un jeu raffiné de lumière et de transparence.





## 08 ACUTO / PURO

### RAGUSA+

- IT Specchio con illuminazione\_Nero opaco.  
EN Mirror with lighting\_Matt black.  
DE Lichtspiegel\_Schwarz matt.  
FR Miroir avec éclairage\_Noir mat.

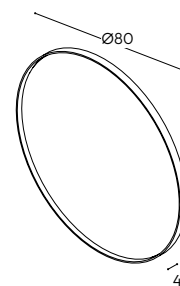

### MITO

- IT Accessori\_Nero opaco / Vetro satinato.  
EN Accessories\_Matt black / Satined Glass.  
DE Accessoires\_Schwarz matt / Satiniertes Glas.  
FR Accessoires\_Noir mat / Verre satiné.

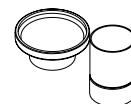

### BOTTICELLI

- IT Lavabo integrato\_Bianco opaco, solid surface.  
EN Integrated washbasin\_Matt white, solid surface.  
DE Integriertes Waschbecken\_Weiß matt, solid surface.  
FR Vasque intégrée\_Blanc mat, solid surface.

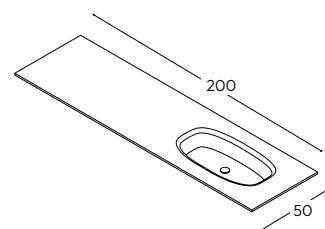

### ACUTO / PURO

- IT Frontali\_TERRA DI LUNA laccato opaco.  
Struttura\_TERRA DI LUNA laccato opaco.  
Mensola\_NOCE NATURALE legno impiallacciato.  
EN Fronts\_TERRA DI LUNA matt lacquer.  
Structure\_TERRA DI LUNA matt lacquer.  
Shelve\_NOCE NATURALE wood veneer.  
DE Fronten\_TERRA DI LUNA matt lackiert.  
Möbelkorpus\_TERRA DI LUNA matt lackiert.  
Ablage\_NOCE NATURALE Furnierholz.  
FR Façades\_TERRA DI LUNA laqué mat.  
Structure\_TERRA DI LUNA laqué mat.  
Étagère\_NOCE NATURALE bois plaqué.

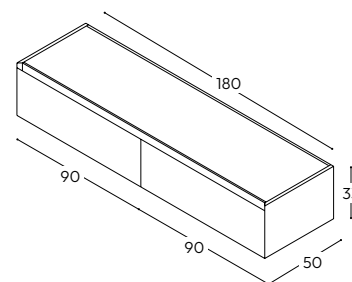

### pag. 083

### INDISSIMA\_WALK IN

- IT Parete doccia\_Walk In: Nero opaco / Vetro cannettato (140x80xH200 cm).  
EN Shower enclosure\_Walk In: Matt black / Fluted glass (140x80xH200 cm).  
DE Duschabtrennung\_Walk In: Matt zwart / Geriffeltes Glas (140x80xH200 cm).  
FR Paroi de douche\_Walk In: Noir mat / Verre cannelé (140x80xH200 cm).

## FINITURE Finishing / Ausführungen / Finitions



NOCE NATURALE

legno impiallacciato / wood veneer /  
Furnierholz / bois plaqué

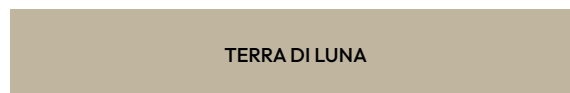

TERRA DI LUNA

laccato opaco / matt lacquered /  
matt lackiert / laqué mat



## 09 ACUTO / PURO

IT UN VOLUME MONOLITICO SI INSERISCE NELLO SPAZIO CON EQUILIBRIO STRUTTURALE E CALMA FORMALE.

EN A monolithic volume fits into the space with structural balance and formal calm.

DE Ein monolithisches Volumen fügt sich in den Raum ein mit strukturellem Gleichgewicht und formaler Ruhe.

FR Un volume monolithique s'inscrit dans l'espace avec équilibre structurel et calme formel.

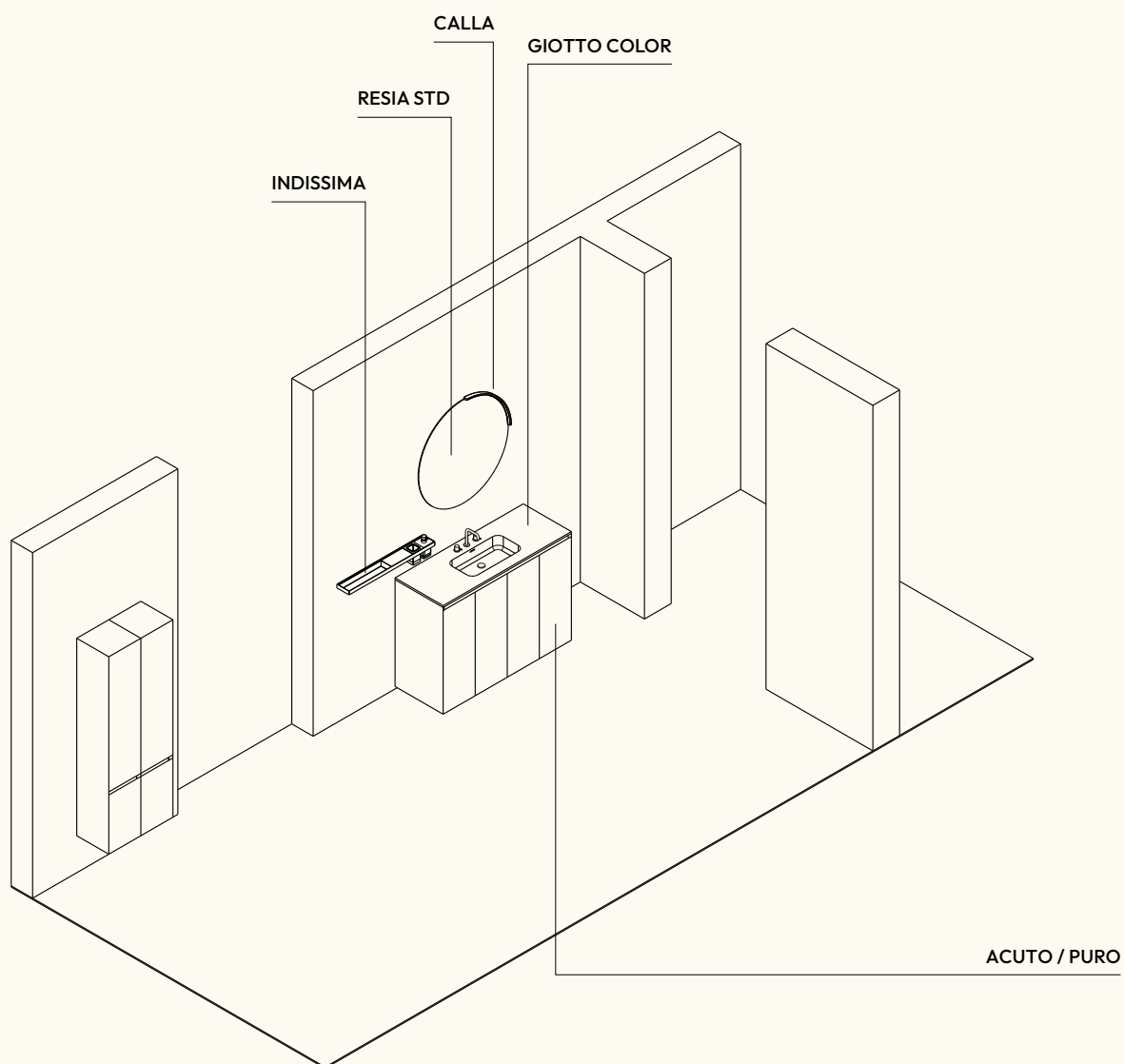







- IT **Frontali e struttura in laccato opaco Perla con piano con lavabo integrato Giotto Color in mineralguss, tonalità Bruno. Accessori Indissima in inox spazzolato. Completano la composizione lo specchio Resia STD e la lampada Calla.**
- EN Fronts and structure in matt lacquer Perla with countertop featuring integrated Giotto Color basin in mineralguss, Bruno shade. Indissima accessories in brushed stainless steel. The composition is completed by the Resia STD mirror and the Calla lamp.
- DE Fronten und Korpus in matt lackiert Perla mit Abdeckplatten mit integriertem Becken Giotto Color aus Mineralguss, Farbton Bruno. Accessoires Indissima aus gebürstetem Edelstahl. Ergänzt wird die Komposition durch den Spiegel Resia STD und die Leuchte Calla.
- FR Façades et structure en laqué mat Perla avec plan avec vasque intégrée Giotto Color en marbre de synthèse, teinte Bruno. Accessoires Indissima en acier inoxydable brossé. La composition est complétée par le miroir Resia STD et la lampe Calla.



- IT **Colonna sospesa in laccato opaco Bruno con quattro ripiani, in dialogo cromatico con il lavabo.**
- EN Wall-mounted tall unit in matt lacquer Bruno with four shelves, in chromatic dialogue with the basin.
- DE Hängende Hochschrank in matt lackiert Bruno mit vier Einlegeböden, im farblichen Dialog mit dem Becken.
- FR Colonne suspendue en laqué mat Bruno avec quatre étagères, en dialogue chromatique avec la vasque.







## 09 ACUTO / PURO

### RESIA STD

- IT Specchio d'arredo.  
 EN Mirror.  
 DE Spiegel.  
 FR Miroir.

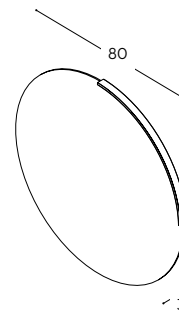

### INDISSIMA

- IT Accessori\_Inox Spazzolato / Vetro satinato.  
 EN Accessories\_Brushed Stainless Steel / Satined Glass.  
 DE Accessoires\_Gebürsteter Edelstahl / Satiniertes Glas.  
 FR Accessoires\_Acier Inoxydable Brossé / Verre satiné.

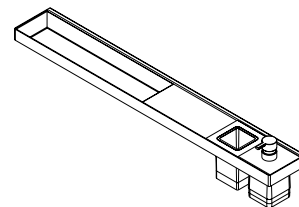

### GIOTTO COLOR

- IT Lavabo integrato\_BRUNO, mineralguss.  
 EN Integrated washbasin\_BRUNO, mineral marble.  
 DE Integriertes Waschbecken\_BRUNO, Mineralguss.  
 FR Vasque intégrée\_BRUNO, marbre de synthèse.

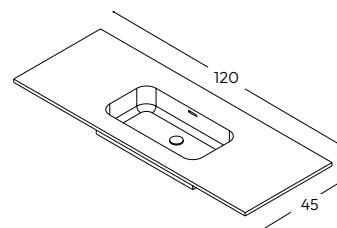

### ACUTO / PURO

- IT Frontali\_PERLA laccato opaco.  
 Struttura\_PERLA laccato opaco.  
 Zoccolo\_Alluminio anodizzato.  
 EN Fronts\_TERRA DI LUNA matt lacquer.  
 Structure\_TERRA DI LUNA matt lacquer.  
 Plinth\_Anodized aluminium.  
 DE Fronten\_TERRA DI LUNA matt lackiert.  
 Möbelkorpus\_TERRA DI LUNA matt lackiert.  
 Sockelleiste\_Anodisiertes Aluminium.  
 FR Façades\_TERRA DI LUNA laqué mat.  
 Structure\_TERRA DI LUNA laqué mat.  
 Plinthe\_Aluminium anodisé.

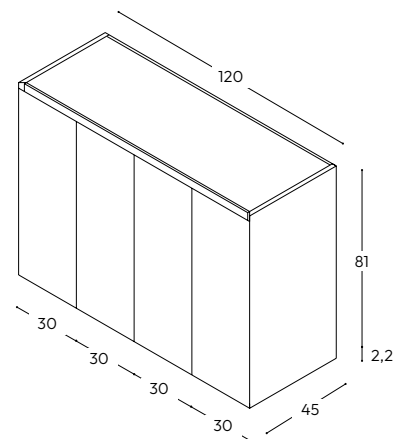

### pag. 093

- IT Colonne\_Frontali e Struttura: BRUNO laccato opaco (30x30xH160 cm).  
 EN Columns\_Fronts and Structure: BRUNO matt lacquer (30x30xH160 cm).  
 DE Hochschränke\_Fronten und Möbelkorpus: BRUNO matt lackiert (30x30xH160 cm).  
 FR Colonnes\_Façade et Structure: BRUNO laqué mat (30x30xH160 cm).

## FINITURE Finishing / Ausführungen / Finitions

PERLA

laccato opaco / matt lacquered /  
matt lackiert / laqué mat

BRUNO

laccato opaco / matt lacquered /  
matt lackiert / laqué mat



# 10 ACUTO / MIDI

IT LINEE PURE E TONALITÀ PROFONDE  
DEFINISCONO UN LINGUAGGIO  
ESSENZIALE, DOVE MATERIA E LUCE  
COSTRUISCONO UN'ELEGANZA  
CONTEMPORANEA.

EN Pure lines and deep tones define an essential language, where material and light shape a contemporary elegance.

DE Reine Linien und tiefe Farbtöne definieren eine essenzielle Formensprache, in der Material und Licht eine zeitgenössische Eleganz formen.

FR Des lignes pures et des tonalités profondes définissent un langage essentiel, où matière et lumière construisent une élégance contemporaine.

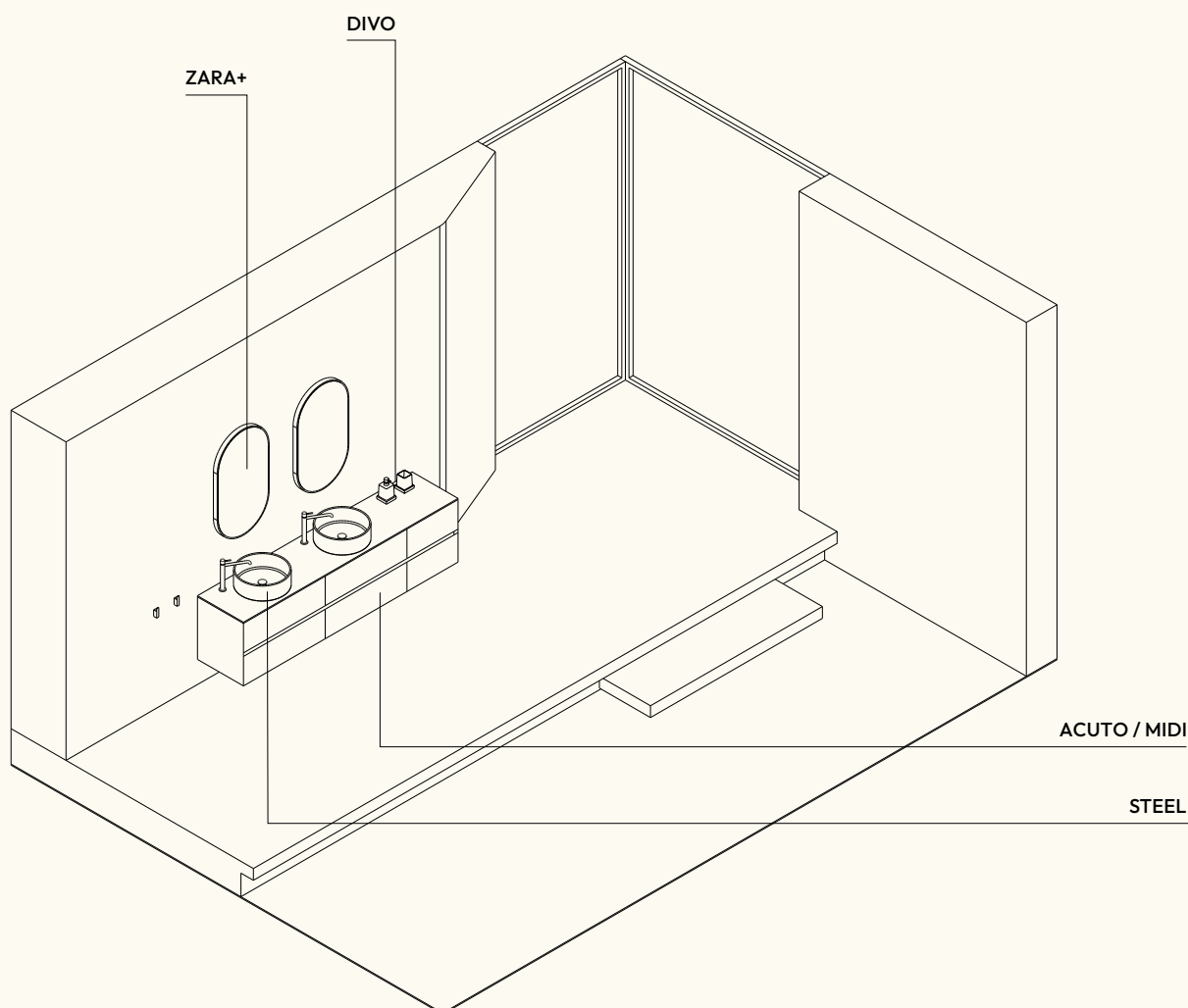





- IT **Frontali in Rovere Chiaro impiallacciato abbinati al lavabo Rodi con top in HPL Nero Cretese. Accessori Divo in finitura nero opaco.**
- EN Fronts in veneered Rovere Chiaro paired with the Rodi basin and top in HPL Nero Cretese. Divo accessories in matt black finish.
- DE Fronten in furniertem Rovere Chiaro kombiniert mit dem Becken Rodi und Abdeckplatten aus HPL Nero Cretese. Accessoires Divo in matt Schwarz Ausführung.
- FR Façades en Rovere Chiaro plaqué associées à la vasque Rodi avec plan en HPL Nero Cretese. Accessoires Divo en finition noir mat.





- IT **La continuità della vena del legno sui frontali definisce una presenza compatta, valorizzata dalla gola MIDI come segno distintivo.**
- EN The continuity of the wood grain across the fronts defines a compact presence, enhanced by the MIDI groove as a distinctive feature.
- DE Die durchgehende Holzmaserung auf den Fronten definiert eine kompakte Präsenz, aufgewertet durch die Griffmulde MIDI als charakteristisches Merkmal.
- FR La continuité du veinage du bois sur les façades définit une présence compacte, valorisée par la prise de mains MIDI comme signe distinctif.





## **10 ACUTO** / MIDI

### ZARA+

- IT Specchio con illuminazione\_Nero opaco.  
EN Mirror with lighting\_Matt black.  
DE Lichtspiegel\_Schwarz matt.  
FR Miroir avec éclairage\_Noir mat.

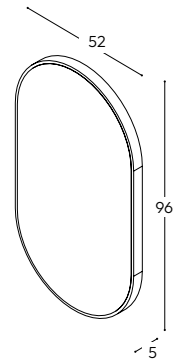

### DIVO

- IT Accessori\_Nero opaco / Vetro satinato.  
EN Accessories\_Matt black / Satined Glass.  
DE Accessoires\_Matt zwart / Satiniertes Glas.  
FR Accessoires\_Noir mat / Verre satiné.

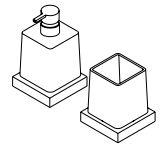

### RODI

- IT Lavabo da appoggio\_Nero opaco, metallo.  
EN Tabletop washbasin\_Matt black, metal.  
DE Aufsatzbecken\_Schwarz matt, Metall.  
FR Vasque à poser\_Noir mat, métal.

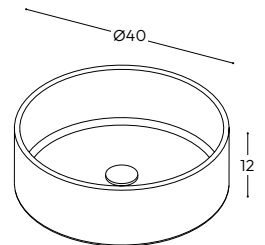

### ACUTO / MIDI

- IT Frontali\_ROVERE CHIARO legno impiallacciato.  
Struttura\_ROVERE CHIARO legno impiallacciato.  
Top\_NERO CRETESE HPL.
- EN Fronts\_ROVERE CHIARO wood veneer.  
Structure\_ROVERE CHIARO wood veneer.  
Worktop\_NERO CRETESE HPL.
- DE Front\_ROVERE CHIARO Furnierholz.  
Möbelkorpus\_ROVERE CHIARO Furnierholz.  
Abdeckplatte\_NERO CRETESE-HPL.
- FR Façades\_ROVERE CHIARO bois plaqué.  
Structure\_ROVERE CHIARO bois plaqué.  
Plan\_HPL NERO CRETESE.

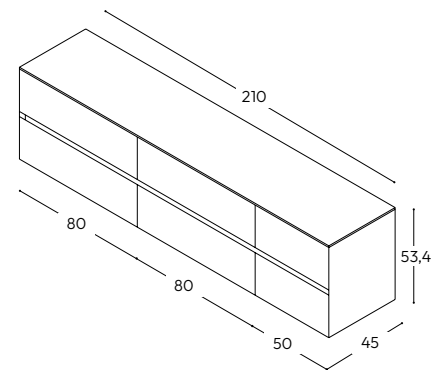

## **FINITURE** Finishing / Ausführungen / Finitions



ROVERE CHIARO

legno impiallacciato / wood veneer /  
Furnierholz / bois plaqué



NERO CRETESE

HPL



IT **GEOMETRIE ESSENZIALI E TONALITÀ CALDE DEFINISCONO UNO SPAZIO DI RAFFINATA PRECISIONE.**

EN Essential geometries and warm tones define a space of refined precision.

DE Essenzielle Geometrien und warme Farbtöne definieren einen Raum von raffinierter Präzision.

FR Des géométries essentielles et des tonalités chaudes définissent un espace d'une précision raffinée.

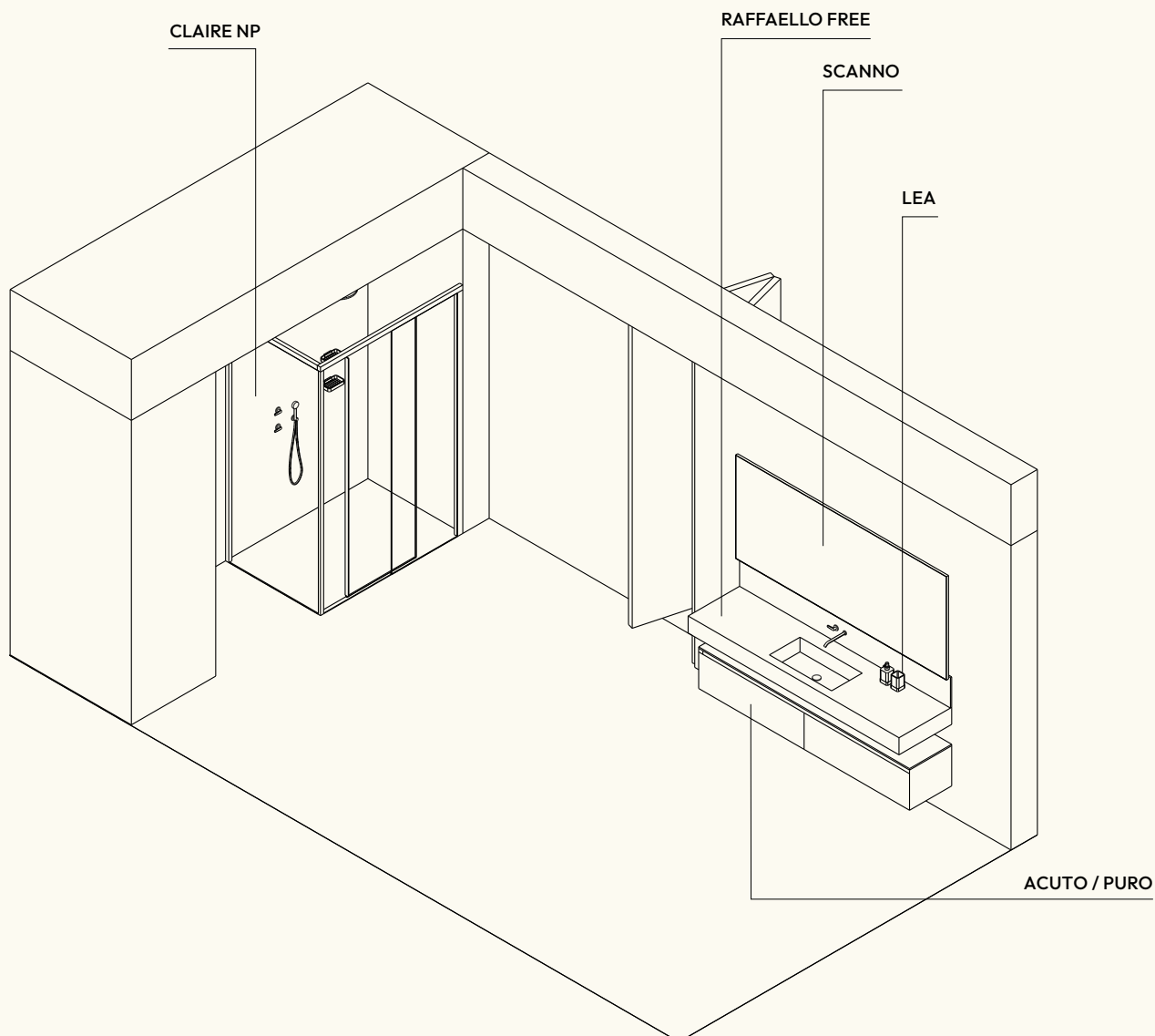







- IT **Frontali in decorativo Rovere Corteccia abbinati al lavabo Raffaello Free con alzatina in gres Travertino bianco. Accessori Lea in oro spazzolato.**
- EN Fronts in Rovere Corteccia decor finish paired with the Raffaello Free basin with backsplash in gres Travertino bianco. Lea accessories in brushed gold finish.
- DE Fronten in Dekor Rovere Corteccia kombiniert mit dem Becken Raffaello Free mit Spritzschutz aus Feinsteinzeug Travertino Bianco. Accessoires Lea in gebürsteter Goldausführung.
- FR Façades en décor Rovere Corteccia associées à la vasque Raffaello Free avec crédence en gres Travertino bianco. Accessoires Lea en finition doré brossé.





- IT **Claire NP in oro spazzolato definisce la parete doccia con un segno elegante e continuo, enfatizzato dalla maniglia a tutta altezza.**
- EN Claire NP in brushed gold defines the shower enclosure with an elegant and continuous line, emphasized by the full-height handle.
- DE Claire NP in gebürstetem Gold definiert die Duschwand mit einer eleganten, durchgehenden Linie, betont durch den Griff über die gesamte Höhe.
- FR Claire NP en doré brossé définit la paroi de douche par un trait élégant et continu, souligné par la poignée sur toute la hauteur.





## 11 ACUTO / PURO

### SCANNO

- IT Specchio d'arredo\_Metal grey.  
 EN Mirror\_Metal grey.  
 DE Spiegel\_Metal grey.  
 FR Miroir\_Metal grey.

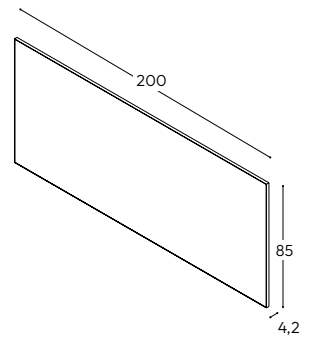

### LEA

- IT Accessori\_Oro spazzolato / Vetro satinato.  
 EN Accessories\_Brushed gilded / Satined Glass.  
 DE Accessoires\_gebürstet Gold / Satiniertes Glas.  
 FR Accessoires\_Doré brossé / Verre satiné.

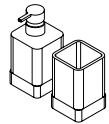

### RAFFAELLO FREE

- IT Consolle con lavabo integrato\_TRAVERTINO BIANCO, gres opaco.  
 EN Console with integrated washbasin\_TRAVERTINO BIANCO, matt gres.  
 DE Integrierte Waschbecken als Freistehende Version\_TRAVERTINO BIANCO, mattes Feinsteinzeug.  
 FR Console avec lavabo intégré\_TRAVERTINO BIANCO, grès mat.

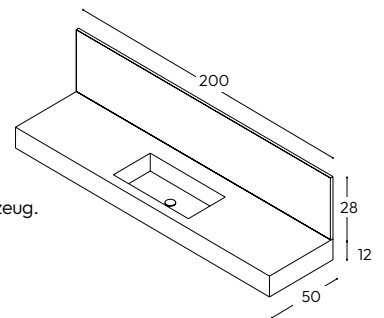

### ACUTO / PURO

- IT Frontali\_ROVERE CORTECCIA decorativo.  
 Struttura\_ROVERE CORTECCIA decorativo.  
 Top\_ROVERE CORTECCIA decorativo.  
 Alzatina\_TRAVERTINO BIANCO, gres opaco.  
 EN Fronts\_ROVERE CORTECCIA decor.  
 Structure\_ROVERE CORTECCIA decor.  
 Worktop\_ROVERE CORTECCIA decor.  
 Backsplash\_TRAVERTINO BIANCO, matt gres.  
 DE Front\_ROVERE CORTECCIA Holzdekor.  
 Möbelkorpus\_ROVERE CORTECCIA Holzdekor.  
 Abdeckplatte\_ROVERE CORTECCIA Holzdekor.  
 Passblende\_TRAVERTINO BIANCO, mattes Feinsteinzeug.  
 FR Façades\_ROVERE CORTECCIA décor bois.  
 Structure\_ROVERE CORTECCIA décor bois.  
 Plan\_ROVERE CORTECCIA décor bois.  
 Rehausse\_TRAVERTINO BIANCO, grès mat.

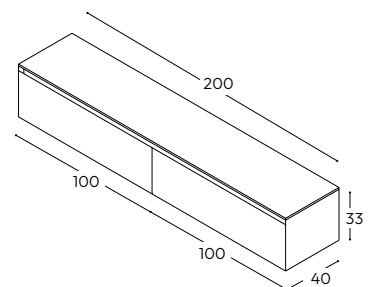

pag. 113

### CLAIRE NP

- IT Parete doccia\_Porta scorrevole: Oro spazzolato / Vetro Trasparente (140x90xH200 cm).  
 EN Shower enclosure\_Sliding door: Brushed Gold / Transparent Glass (140x90xH200 cm).  
 DE Duschabtrennung\_Schiebetür: Gebürstetes Gold / Klarglas (140x90xH200 cm).  
 FR Paroi de douche\_Porte coulissante: Doré Brossé / Verre Transparent (140x90xH200 cm).

## FINITURE Finishing / Ausführungen / Finitions



ROVERE CORTECCIA

decorativo / decor /  
 Holzdekor / décor bois

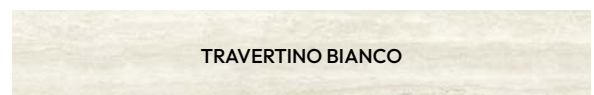

TRAVERTINO BIANCO

gres opaco / matt gres /  
 Feinsteinzeug matte / grès mat



# 12 ACUTO / PURO

IT LINEE DECISE E VOLUMI ESSENZIALI  
DEFINISCONO UNA PRESENZA  
COMPATTA E CONTEMPORANEA.

EN Bold lines and essential volumes define a compact and contemporary presence.

DE Klare Linien und essenzielle Volumen definieren eine kompakte und zeitgemäße Präsenz.

FR Des lignes affirmées et des volumes essentiels définissent une présence compacte et contemporaine.

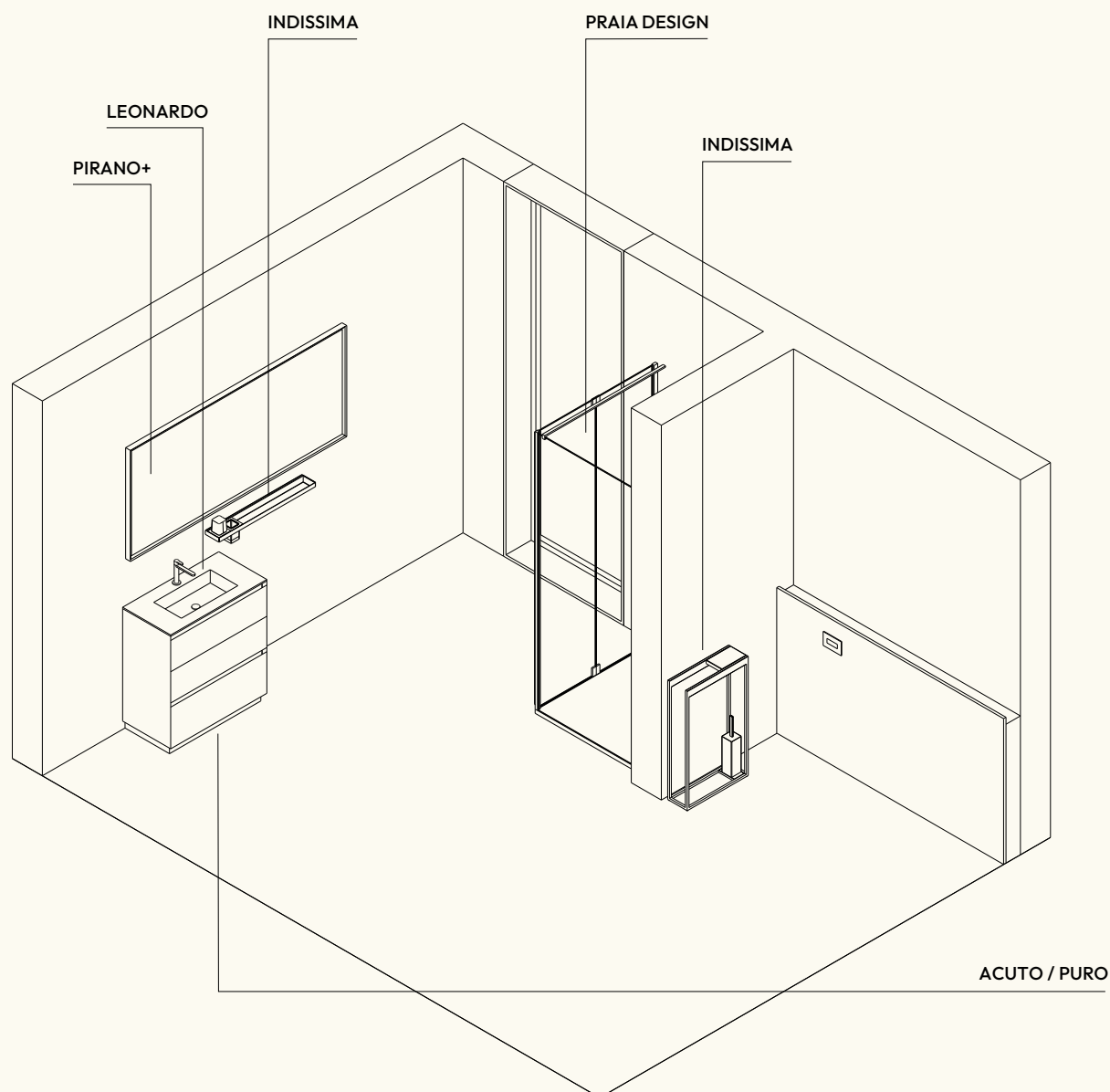







- IT **Frontali laccati Verde Bosco con lavabo integrato Leonardo in HPL Pietra Scura, nella versione con base a tre cassetti su zoccolo a terra.**
- EN Lacquered Verde Bosco fronts with integrated Leonardo basin in HPL Pietra Scura, in the version with three-drawer base on floor plinth.
- DE Lackierte Fronten in Verde Bosco mit integriertem Becken Leonardo aus HPL Pietra Scura, in der Version mit dreischübiger Base auf Sockel stehend.
- FR Façades laquées Verde Bosco avec vasque intégrée Leonardo en HPL Pietra Scura, dans la version avec base à trois tiroirs sur socle au sol.





- IT **Barra modulare Indissima con luce LED, personalizzabile con moduli portasalviette, spandisapone e bicchiere in finitura nero opaco, coordinata con Pirano+ nella medesima finitura.**
- EN Indissima modular bar with LED light, customizable with towel holder, soap dispenser and tumbler modules in matt black finish, coordinated with Pirano+ in the same finish.
- DE Modulare Stange Indissima mit LED-Licht, individuell konfigurierbar mit Handtuchhalter-, Seifenspender- und Bechermodule in matt Schwarz Ausführung, abgestimmt auf Pirano+ in derselben Ausführung.
- FR Barre modulaire Indissima avec éclairage LED, personnalisable avec modules porte-serviettes, distributeur de savon et gobelet en finition noir mat, coordonnée avec Pirano+ dans la même finition.





IT **Praia Design, con il suo stile elegante e pulito, caratterizzato dalle cerniere, crea un'estetica raffinata e distintiva.**

EN Praia Design, with its elegant and clean style, characterized by the hinges, creates a refined and distinctive aesthetic.

DE Praia Design mit seinem eleganten und klaren Stil, geprägt durch die Scharniere, schafft eine raffinierte und unverwechselbare Ästhetik.

FR Praia Design, avec son style élégant et épuré, caractérisé par les charnières, crée une esthétique raffinée et distinctive.





## 12 ACUTO / PURO

### PIRANO+

- IT Specchio con illuminazione\_Nero opaco.  
EN Mirror with lighting\_Matt black.  
DE Lichtspiegel\_schwarz matt.  
FR Miroir avec éclairage\_Noir mat.

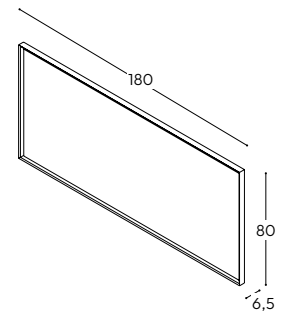

### INDISSIMA

- IT Accessori\_Nero opaco / Vetro satinato.  
EN Accessories\_Matt black / Satined Glass.  
DE Accessoires\_schwarz matt / Satiniertes Glas.  
FR Accessoires\_Noir mat / Verre satiné.

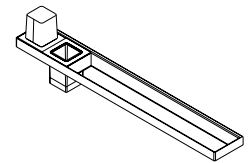

### LEONARDO

- IT Lavabo integrato\_PIETRA SCURA, HPL.  
EN Integrated washbasin\_HPL-PIETRA SCURA.  
DE Integriertes Waschbecken\_PIETRA SCURA-HPL.  
FR Vasque intégrée\_PIETRA SCURA, HPL.

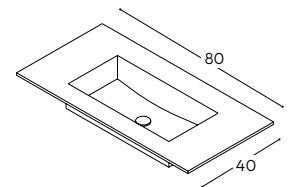

### ACUTO / PURO

- IT Frontali\_VERDE BOSCO laccato opaco.  
Struttura\_VERDE BOSCO laccato opaco.  
Zoccolo\_VERDE BOSCO laccato opaco.  
EN Fronts\_VERDE BOSCO matt lacquer.  
Structure\_VERDE BOSCO matt lacquer.  
Plinth\_VERDE BOSCO matt lacquer.  
DE Fronten\_VERDE BOSCO matt lackiert.  
Möbelkorpus\_VERDE BOSCO matt lackiert.  
Sockelleiste\_VERDE BOSCO matt lackiert.  
FR Façades\_VERDE BOSCO laqué mat.  
Structure\_VERDE BOSCO laqué mat.  
Plinthe\_VERDE BOSCO laqué mat.

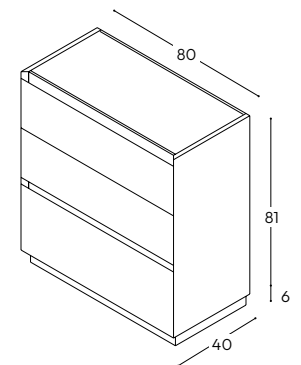

### pag. 125

### PRAIA DESIGN

- IT Parete doccia\_Porta a soffietto: Gun Metal spazzolato / Vetro Trasparente (100x90xH200 cm).  
EN Shower enclosure\_Folding door: Brushed Gun Metal / Transparent Glass (100x90xH200 cm).  
DE Duschabtrennung\_Faltrittür: Gebürstetes Gun Metal / Klarglas (100x90xH200 cm).  
FR Paroi de douche\_Porte pliante: Gun Metal Brossé / Verre Transparent (100x90xH200 cm).

## FINITURE Finishing / Ausführungen / Finitions

VERDE BOSCO

laccato opaco / matt lacquered /  
matt lackiert / laqué mat

PIETRA SCURA

HPL



# 13 ACUTO / MIDI

IT SUPERFICI CHIARE E FINITURE  
A CONTRASTO COSTRUISCONO  
UN EQUILIBRIO DAL CARATTERE  
ESSENZIALE.

EN Light surfaces and contrasting finishes create a balance with an essential character.

DE Helle Oberflächen und kontrastierende Ausführungen schaffen ein Gleichgewicht mit wesentlichem Charakter.

FR Des surfaces claires et des finitions contrastées créent un équilibre au caractère essentiel.

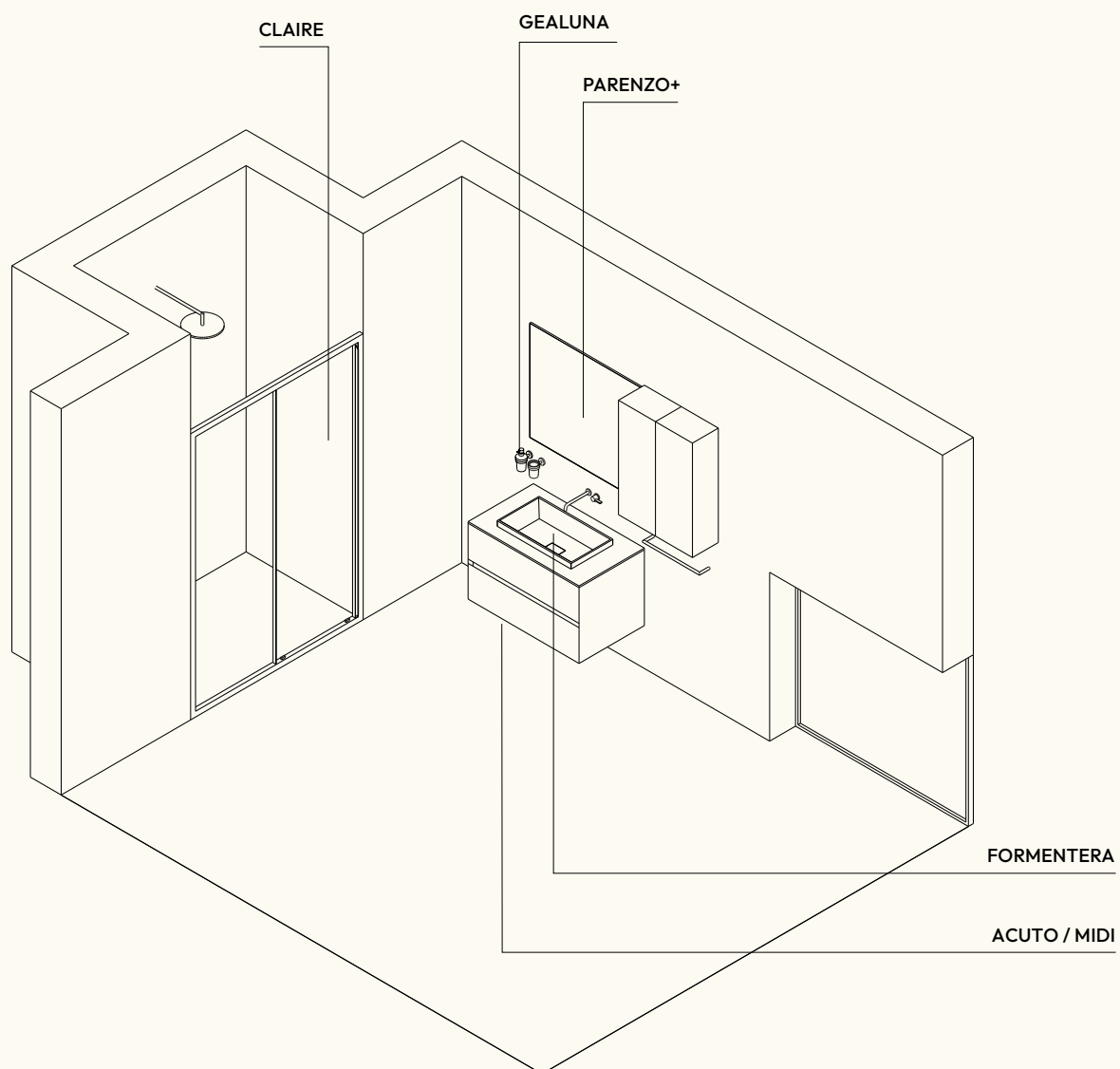







- IT **Frontali in laccato opaco Cemento con top in mineralguss Cemento e lavabo semi-incassato Formentera in color Grafite, in un raffinato contrasto cromatico. Pensili in color Grafite in continuità con il lavabo.**
- EN Fronts in matt lacquer Cemento with top in mineralguss Cemento and semi-recessed Formentera basin in color Grafite, creating a refined chromatic contrast. Wall units in color Grafite in continuity with the basin.
- DE Fronten in matt lackiert Cemento mit Abdeckplatten aus Mineralguss Cemento und halb eingelassenem Becken Formentera in Farbe Grafite, in einem raffinierten farblichen Kontrast. Hängeschränke in Farbe Grafite in Kontinuität mit dem Becken.
- FR Façades en laqué mat Cemento avec plan en marbre de synthèse Cemento et vasque semi-encastree Formentera en color Grafite, dans un raffiné contraste chromatique. Meubles hauts en color Grafite en continuité avec la vasque.





IT **Claire, nella versione per nicchia, definisce lo spazio doccia con una maniglia a tutta altezza, segno di raffinata essenzialità.**

EN Claire, in the niche version, defines the shower space with a full-height handle, a sign of refined essentiality.

DE Claire definiert in der Nischenversion den Duschbereich mit einem griff über die gesamte Höhe – ein Zeichen raffinierter Schlichtheit.

FR Claire, dans la version pour niche, définit l'espace douche grâce à une poignée sur toute la hauteur, signe d'une élégante essentialité.





## **13 ACUTO** / MIDI

### **PARENZO+**

- IT Specchio con illuminazione\_Metal grey.  
EN Mirror with lighting\_Metal grey.  
DE Lichtspiegel\_Metal grey.  
FR Miroir avec éclairage\_Metal grey.

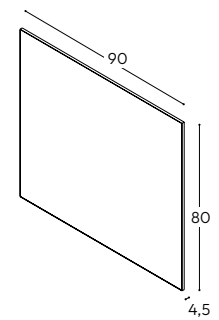

### **GEALUNA**

- IT Accessori\_GRAFITE / Vetro Trasparente.  
EN Accessories\_GRAFITE / Transparent Glass.  
DE Accessoires\_GRAFITE / Transparentes Glas.  
FR Accessoires\_GRAFITE / Verre Transparent.



### **FORMENTERA**

- IT Lavabo da appoggio semi-integrato\_GRAFITE, mineralguss.  
EN Semi-integrated countertop washbasin\_GRAFITE, mineral marble.  
DE Halbintegriertes Aufsatzwaschbecken\_GRAFITE, Mineralguss.  
FR Vasque à poser semi-intégré\_GRAFITE, marbre de synthèse.

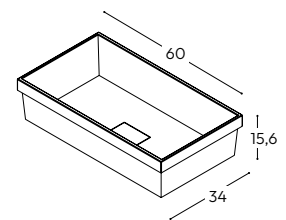

### **ACUTO / MIDI**

- IT Frontali\_CEMENTO laccato opaco.  
Struttura\_CEMENTO laccato opaco.  
Top\_CEMENTO, mineralguss.  
EN Fronts\_CEMENTO matt lacquer.  
Structure\_CEMENTO matt lacquer.  
Worktop\_CEMENTO, mineral marble.  
DE Fronten\_CEMENTO matt lackiert.  
Möbelkorpus\_CEMENTO matt lackiert.  
Abdeckplatte\_CEMENTO, Mineralguss.  
FR Façades\_CEMENTO laqué mat.  
Structure\_CEMENTO laqué mat.  
Plan\_CEMENTO, marbre de synthèse.

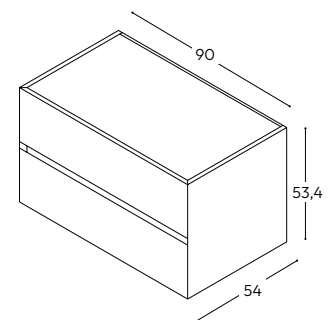

### **pag. 132**

- IT Pensile con anta\_Frontali: GRAFITE laccato opaco. / Struttura: GRAFITE laccato opaco (30x30xH80 cm).  
EN Wall unit\_Fronts: GRAFITE matt lacquered. / Structure: GRAFITE matt lacquered (30x30xH80 cm).  
DE Hängeschränke mit Tür\_Fronten: GRAFITE matt lackiert. / Möbelkorpus: GRAFITE matt lackiert (30x30xH80 cm).  
FR Meuble hauts avec porte\_Façade: GRAFITE laqué mat. / Structure: GRAFITE laqué mat (30x30xH80 cm).

### **pag. 135**

#### **CLAIRE**

- IT Parete doccia\_Porta scorrevole: GRAFITE / Vetro Trasparente (140x90xH200 cm).  
EN Shower enclosure\_Sliding door: GRAFITE / Transparent Glass (140x90xH200 cm).  
DE Duschtrennung\_Schiebetür für Nische: GRAFITE / Klarglas (140x90xH200 cm).  
FR Paroi de douche\_Porte coulissante: GRAFITE / Verre Transparent (140x90xH200 cm).

## **FINITURE** Finishing / Ausführungen / Finitions

**CEMENTO**

**GRAFITE**

laccato opaco / matt lacquered /  
matt lackiert / laqué mat

laccato opaco / matt lacquered /  
matt lackiert / laqué mat



# 14 ACUTO / PURO

IT VOLUMI SOVRAPPOSTI E MATERIE  
A CONTRASTO DEFINISCONO  
UNA COMPOSIZIONE  
DI ELEGANTE EQUILIBRIO.

EN Overlapping volumes and contrasting materials define a composition of elegant balance.

DE Übereinanderliegende Volumen und kontrastierende Materialien definieren eine Komposition von eleganter Ausgewogenheit.

FR Des volumes superposés et des matières contrastées définissent une composition d'un élégant équilibre.

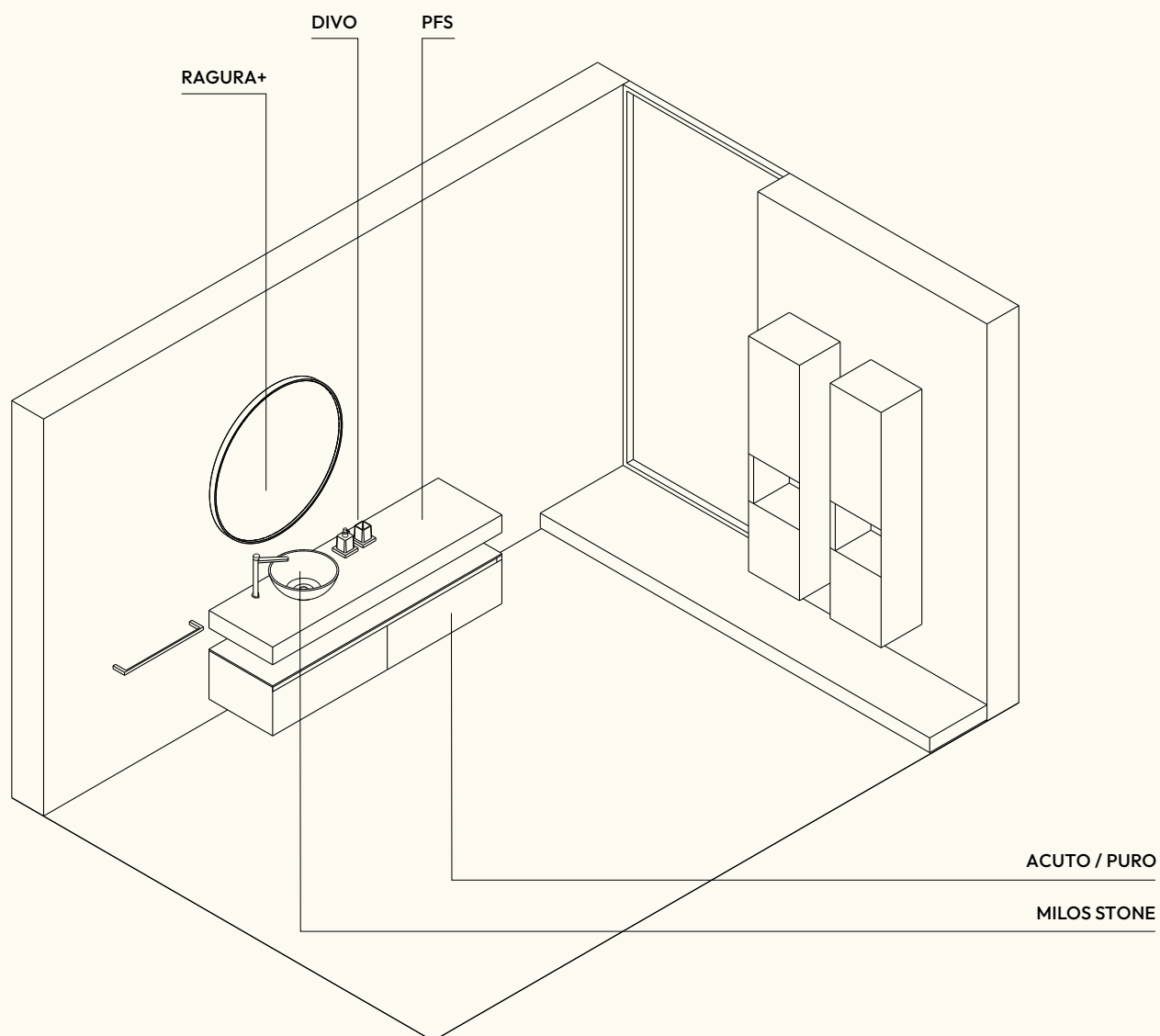







- IT **Frontali in laccato opaco Terra di Luna con consolle PFS (Piano Forte Spessore) da 12 cm in legno impiallacciato Noce Naturale. Lavabo d'appoggio Milos Stone, finitura Creta. Accessori Divo in bronzo spazzolato.**
- EN **Fronts in matt lacquer Terra di Luna with PFS console (shelf) 12 cm thick in veneered Noce Naturale wood. Milos Stone countertop basin, Creta finish. Divo accessories in brushed bronze.**
- DE **Fronten in matt lackiert Terra di Luna mit Konsole PFS (Ablage) 12 cm stark aus furniertem Noce Naturale. Aufsatzbecken Milos Stone, Ausführung Creta. Accessoires Divo in gebürstetem Bronze.**
- FR **Façades en laqué mat Terra di Luna avec console PFS (étagère) de 12 cm en bois plaqué Noce Naturale. Vasque à poser Milos Stone, finition Creta. Accessoires Divo en bronze brossé.**



- IT **Colonne sospese in laccato opaco Terracotta con vano a giorno centrale e illuminazione ambientale.**
- EN Wall-mounted tall units in matt lacquer Terracotta with central open compartment featuring ambient lighting.
- DE Hängende Hochschränke in matt lackiert Terracotta mit mittlerem offenem Fach und Ambientebeleuchtung.
- FR Colonnes suspendues en laqué mat Terracotta avec niche centrale ouverte et éclairage d'ambiance.





## 14 ACUTO / PURO

### RAGUSA+

- IT Specchio con illuminazione\_Bronzo spazzolato.  
 EN Mirror with lighting\_Brushed Bronze.  
 DE Lichtspiegel\_Gebürstete Bronze.  
 FR Miroir avec éclairage\_Bronze Brossé.

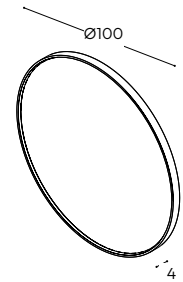

### DIVO

- IT Accessori\_Bronzo spazzolato / Vetro Trasparente.  
 EN Accessories\_Brushed Bronze / Transparent Glass.  
 DE Accessoires\_Gebürstete Bronze / Transparentes Glas.  
 FR Accessoires\_Bronze Brossé / Verre Transparent.

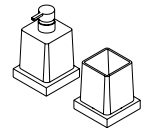

### MILOS STONE

- IT Lavabo da appoggio\_CRETA, ceramica.  
 EN Tabletop washbasin\_CRETA, ceramic.  
 DE Aufsatzbecken\_CRETA, Keramik.  
 FR Vasque à poser\_CRETA, céramique.

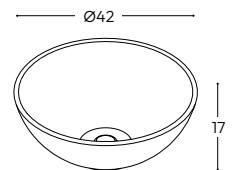

### ACUTO / PURO

- IT Frontali\_TERRA DI LUNA laccato opaco.  
 Struttura\_TERRA DI LUNA laccato opaco.  
 Top\_TERRA DI LUNA laccato opaco.  
 PFS\_NOCE NATURALE legno impiallacciato.  
 EN Fronts\_TERRA DI LUNA matt lacquer.  
 Structure\_TERRA DI LUNA matt lacquer.  
 Worktop\_TERRA DI LUNA mineral marble.  
 PFS\_NOCE NATURALE wood veneer.  
 DE Fronten\_TERRA DI LUNA matt lackiert.  
 Möbelkorpus\_TERRA DI LUNA matt lackiert.  
 Abdeckplatte\_TERRA DI LUNA matt lackiert.  
 PFS\_NOCE NATURALE Furnierholz.  
 FR Façades\_TERRA DI LUNA laqué mat.  
 Structure\_TERRA DI LUNA laqué mat.  
 Plan\_TERRA DI LUNA laqué mat.  
 PFS\_NOCE NATURALE bois plaqué.

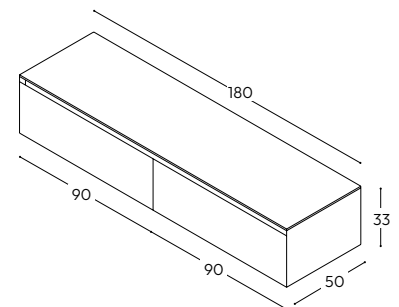

### pag. 145

- IT Colonne con vani a giorno\_Frontali e Struttura: TERRACOTTA laccato opaco (40x32xH160 cm).  
 EN Columns and open compartments\_Fronts and Structure: TERRACOTTA matt lacquer (40x32xH160 cm).  
 DE Hochschränke und offene Fächer\_Fronten und Möbelkorpus: TERRACOTTA matt lackiert (40x32xH160 cm).  
 FR Colonnes et compartiments ouverts\_Façade et Structure: TERRACOTTA laqué mat (40x32xH160 cm).

## FINITURE Finishing / Ausführungen / Finitions



NOCE NATURALE

legno impiallacciato / wood veneer /  
 Furnierholz / bois plaqué



TERRA DI LUNA

laccato opaco / matt lacquered /  
 matt lackiert / laqué mat



# 15 ACUTO / DUAL

IT UNO SPAZIO ARMONICO PRENDE FORMA  
ATTRAVERSO PROPORZIONI  
STUDIATE E FINITURE ARTICOLATE,  
INTERPRETE DI UNA VISIONE  
PROGETTUALE.

EN A harmonious space takes shape through studied proportions  
and articulated finishes, expressing a design vision.

DE Ein harmonischer Raum entsteht durch durchdachte Proportionen  
und differenzierte Ausführungen, als Ausdruck einer  
gestalterischen Vision.

FR Un espace harmonieux prend forme à travers des proportions étudiées  
et des finitions articulées, interprète d'une vision de projet.

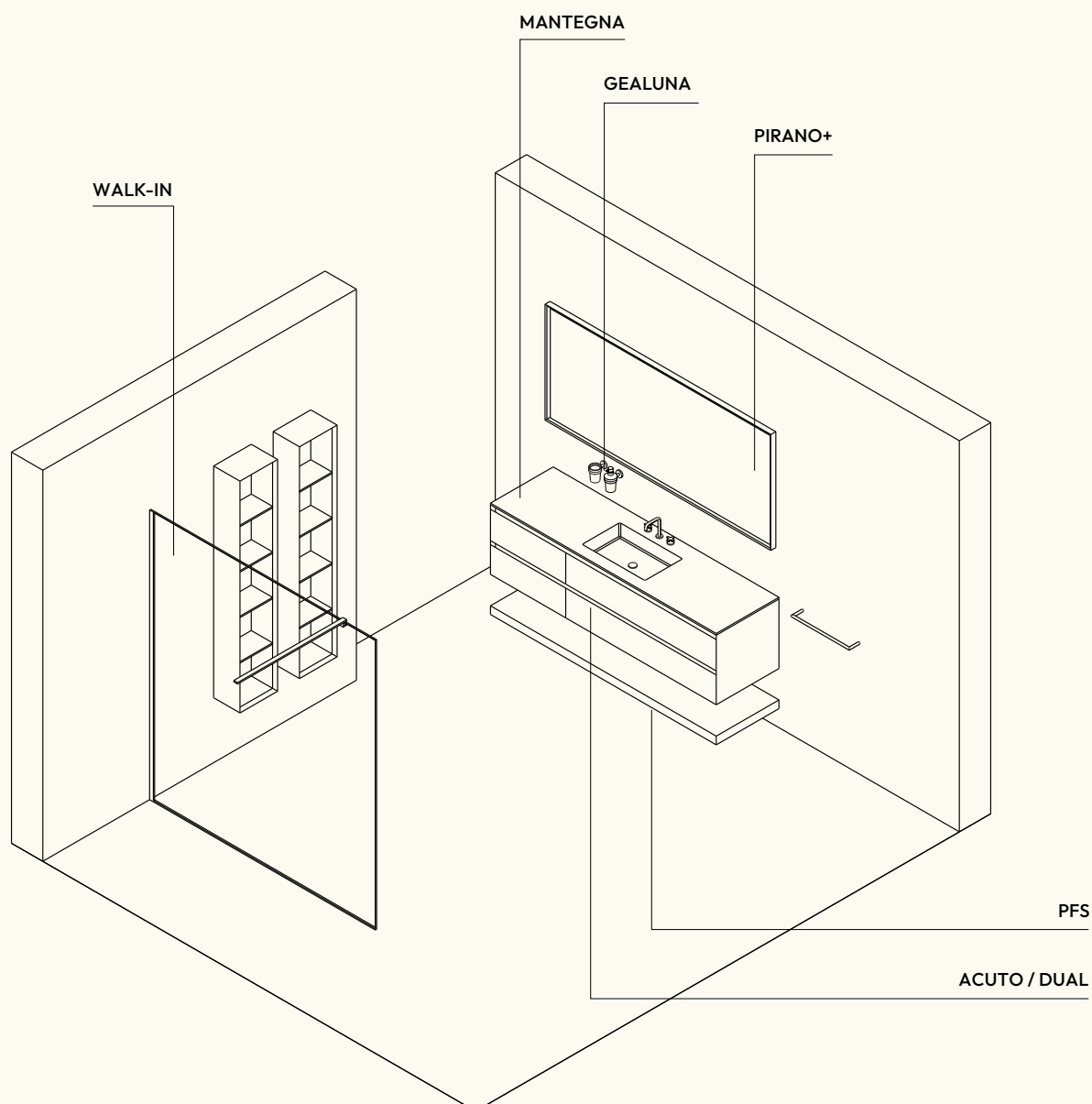









- IT** Frontali in decorativo Quercia Nature con consolle PFS (Piano Forte Spessore) da 6 cm di spessore nella stessa finitura. Lavabo integrato Mantegna in solid surface bianco opaco. Accessori Gealuna in nero opaco.
- EN** Fronts in Quercia Nature decor finish with PFS console (shelf) 6 cm thick in the same finish. Integrated Mantegna basin in matt white solid surface. Gealuna accessories in matt black.
- DE** Fronten in Dekor Quercia Nature mit Konsole PFS (Ablage) 6 cm stark in derselben Ausführung. Integriertes Becken Mantegna aus Solid Surface matt Weiß. Accessoires Gealuna in matt Schwarz.
- FR** Façades en décor Quercia Nature avec console PFS (étagère) de 6 cm d'épaisseur dans la même finition. Vasque intégrée Mantegna en solid surface blanc mat. Accessoires Gealuna en noir mat.



- IT **Vani a giorno in laccato opaco Verde Bosco: elementi aperti per organizzare e dare ritmo alla composizione, con una nota cromatica naturale nell'ambiente.**
- EN Open compartments in matt lacquer Verde Bosco: open elements to organise and add rhythm to the composition, bringing a natural chromatic note to the space.
- DE Offene Fächer in matt lackiertem Verde Bosco: offene Elemente zum Ordnen und zur Belebung der Komposition, mit einer natürlichen farblichen Note im Raum.
- FR Niches ouvertes en laqué mat Verde Bosco: éléments ouverts pour organiser et rythmer la composition, apportant une note chromatique naturelle à l'espace.

- IT **Walk-in con vetro Sfumato Nuvola crea un sottile gioco di vedo e non vedo, definendo un'atmosfera intima e raffinata.**
- EN Walk-in with Cloud gradient glass creates a subtle interplay of reveal and conceal, defining an intimate and refined atmosphere.
- DE Die Walk-in mit Glas Wolkenverlauf erzeugt ein feines Spiel von Sehen und Nichtsehen und schafft eine intime und raffinierte Atmosphäre.
- FR La Walk-in avec verre Nuage dégradé crée un subtil jeu de voir et de ne pas voir, créant une atmosphère intime et raffinée.





## 15 ACUTO / DUAL

### PIRANO+

- IT Specchio con illuminazione\_Nero opaco.  
 EN Mirror with lighting\_Matt black.  
 DE Lichtspiegel\_Schwarz matt.  
 FR Miroir avec éclairage\_Noir mat.

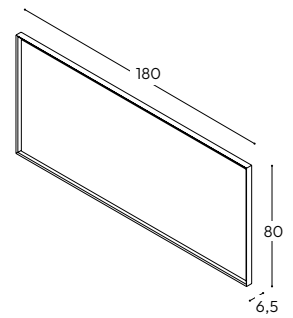

### GEALUNA

- IT Accessori\_Nero opaco / Vetro extrachiaro trasparente.  
 EN Accessories\_Matt black / Extra clear transparent glass.  
 DE Accessoires\_Schwarz matt / Transparentes Glas, extra klar.  
 FR Accessoires\_Noir mat / Verre transparent extra clair.



### MANTEGNA

- IT Lavabo integrato\_Bianco opaco, solid surface.  
 EN Integrated washbasin\_Matt white, solid surface.  
 DE Integriertes Waschbecken\_Weiß matt, Solid Surface.  
 FR Vasque intégrée\_Blanc mat, solid surface.

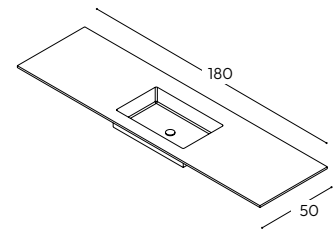

### ACUTO / PURO

- IT Frontali\_QUERCIA NATURE decorativo.  
 Struttura\_QUERCIA NATURE decorativo.  
 PFS\_QUERCIA NATURE decorativo.  
 EN Fronts\_QUERCIA NATURE decor.  
 Structure\_QUERCIA NATURE decor.  
 PFS\_QUERCIA NATURE decor.  
 DE Fronten\_QUERCIA NATURE Holzdekor.  
 Möbelkorpus\_QUERCIA NATURE Holzdekor.  
 PFS\_QUERCIA NATURE Holzdekor.  
 FR Façades\_QUERCIA NATURE décor bois.  
 Structure\_QUERCIA NATURE décor bois.  
 PFS\_QUERCIA NATURE décor bois.

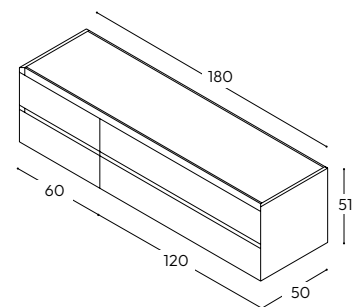

### pag. 154

- IT Vani a giorno\_VERDE BOSCO laccato opaco (30x21xH160 cm).  
 EN Open compartments\_VERDE BOSCO matt lacquer (30x21xH160 cm).  
 DE Offene Fächer\_VERDE BOSCO matt lackiert (30x21xH160 cm).  
 FR Compartiments ouverts\_VERDE BOSCO laqué mat (30x21xH160 cm).

### pag. 157

#### WALK IN

- IT Parete doccia\_Walk In: Nero / Sfumato Nuvola (140x80xH200 cm).  
 EN Shower enclosure\_Walk In: Black / Cloud Gradient (140x80xH200 cm).  
 DE Duschabtrennung\_Walk In: Schwarz / Wolkenverlauf (140x80xH200 cm).  
 FR Paroi de douche\_Walk In: Noir / Nuage Dégradé (140x80xH200 cm).

## FINITURE Finishing / Ausführungen / Finitions



QUERCIA NATURALE

decorativo / decor /  
 Holzdekor / décor bois



VERDE BOSCO

laccato opaco / matt lacquered /  
 matt lackiert / laqué mat



# 16 ACUTO / PURO

IT UN AMBIENTE DI EQUILIBRIO  
MATERICO, DOVE LINEE ESSENZIALI  
DIALOGANO CON LA PRESENZA  
INTENSA DEL GRES.

EN A space of material balance, where essential lines engage in dialogue with the intense presence of gres.

DE Ein Raum von materiellem Gleichgewicht, in dem essenzielle Linien mit der intensiven Präsenz des Feinsteinzeugs in Dialog treten.

FR Un espace d'équilibre matériel, où des lignes essentielles dialoguent avec la présence intense du gres.

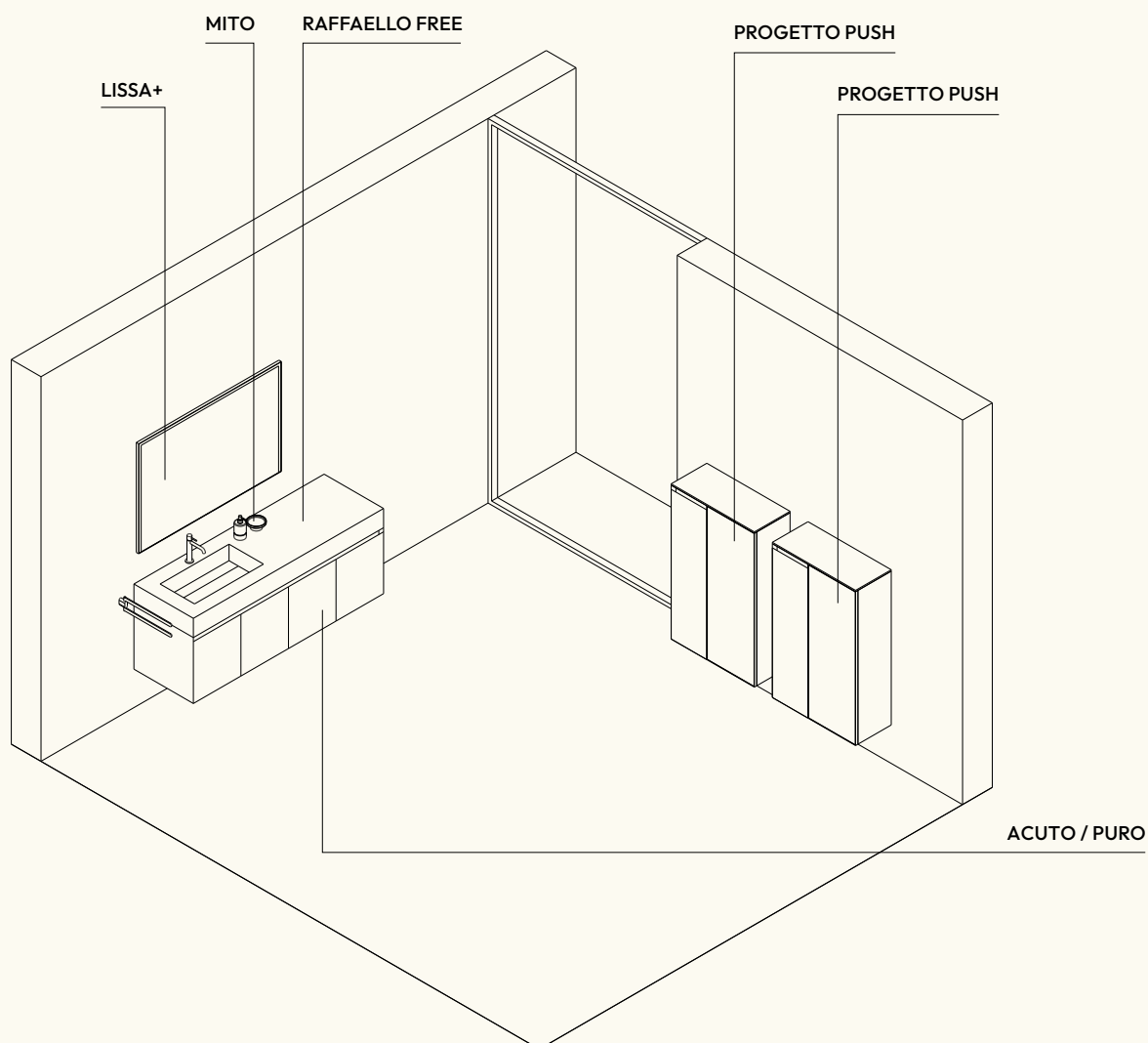







- IT **Frontali in decorativo Larice Cannella. Lavabo Raffaello Free in gres Verde Alpino lucido. Accessori Mito in nickel spazzolato. Specchio Lissa+ in inox spazzolato.**
- EN **Fronts in Larice Cannella decor finish. Raffaello free basin in glossy Verde Alpino gres. Mito accessories in brushed nickel. Lissa+ mirror in brushed stainless steel.**
- DE **Fronten in Dekor Larice Cannella. Freistehendes Becken Raffaello Free aus glänzendem Feinsteinzeug Verde Alpino. Accessoires Mito aus gebürstetem Nickel. Spiegel Lissa+ aus gebürstetem Edelstahl.**
- FR **Façades en décor Larice Cannella. Vasque Raffaello Free en grès Verde Alpino brillant. Accessoires Mito en nickel brossé. Miroir Lissa+ en acier inoxydable brossé.**





- IT **Coppia di colonne con ripiani in vetro: la prima con frontali in decorativo Larice Cannella e specchio interno; la seconda con apertura push, frontali in vetro fumé e telaio nero opaco con illuminazione interna.**
- EN Pair of tall units with glass shelves: the first with fronts in Larice Cannella decor finish and internal mirror; the second with push opening, smoked glass fronts and matt black frame with internal lighting.
- DE Paar Hochschränke mit Glasböden: der erste mit Fronten in Dekor Larice Cannella und Innenspiegel; der zweite mit Push-Öffnung, Fronten aus Rauchglas und Rahmen in matt Schwarz mit Innenbeleuchtung.
- FR Paire de colonnes avec étagères en verre : la première avec façades en décor Larice Cannella et miroir intérieur ; la seconde avec ouverture push, façades en verre fumé et cadre noir mat avec éclairage intérieur.





## 16 ACUTO / PURO

### LISSA+

- IT Specchio con illuminazione\_Inox Spazzolato.  
 EN Mirror with lighting\_Brushed Stainless Steel.  
 DE Lichtspiegel\_Gebürsteter Edelstahl.  
 FR Miroir avec éclairage\_Acier Inoxydable Brossé.

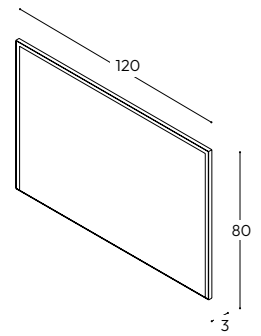

### MITO

- IT Accessori\_Nickel spazzolato / Vetro satinato.  
 EN Accessories\_Brushed Nickel / Satined Glass.  
 DE Accessoires\_Gebürstetes Nickel / Satiniertes Glas.  
 FR Accessoires\_Nickel Brossé / Verre satiné.



### RAFFAELLO FREE

- IT Consolle con lavabo integrato\_VERDE ALPINO, gres lucido.  
 EN Console with integrated washbasin\_VERDE ALPINO, glossy gres.  
 DE Integriertes Waschbecken als Freistehende Version\_VERDE ALPINO Feinsteinzeug glänzend.  
 FR Console avec lavabo intégré\_VERDE ALPINO, gres brillant.

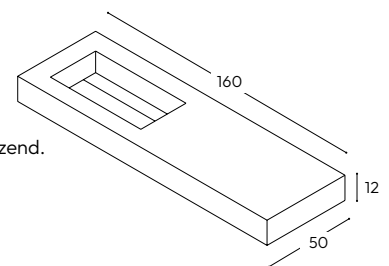

### ACUTO / PURO

- IT Basi con anta:  
 Frontali\_LARICE CANNELLA decorativo.  
 Struttura\_LARICE CANNELLA decorativo.  
 EN Base units with door:  
 Fronts\_LARICE CANNELLA decor.  
 Structure\_LARICE CANNELLA decor.  
 DE Unterschränke mit Türen:  
 Fronten\_LARICE CANNELLA Holzdekor.  
 Möbelkorpus\_LARICE CANNELLA Holzdekor.  
 FR Meubles bas avec porte:  
 Façades\_LARICE CANNELLA décor bois.  
 Structure\_LARICE CANNELLA décor bois.

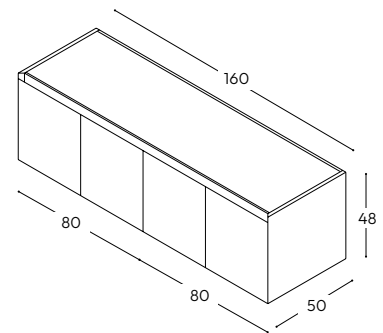

### pag. 167

- IT Colonne ACUTO\_Frontali e Struttura: LARICE CANNELLA decorativo (30x30xH112 cm).  
 Colonne PROGETTO PUSH\_Frontali: FUMÉ semi-trasparente, su telaio in finitura nero.  
 / Struttura: LARICE CANNELLA decorativo / Top: LARICE CANNELLA decorativo (40x30xH112 cm).  
 EN Columns ACUTO\_Fronts and Structure: LARICE CANNELLA decor (30x30xH112 cm).  
 Column PROGETTO PUSH\_Fronts: Semi-transparent FUMÉ glass on frame in black finish.  
 / Structure: LARICE CANNELLA decor / Worktop: LARICE CANNELLA decor (40x30xH112 cm).  
 DE Hochschränke ACUTO\_Fronten und Möbelkorpus: LARICE CANNELLA Holzdekor (30x30xH112 cm).  
 Hochschrank PROGETTO PUSH\_Fronten: Fuméglass mit schwarzem Rahmen.  
 / Möbelkorpus: LARICE CANNELLA Holzdekor / Abdeckplatte: LARICE CANNELLA Holzdekor (40x30xH112 cm).  
 FR Colonnes ACUTO\_Façade et Structure: LARICE CANNELLA décor bois (30x30xH112 cm).  
 Colonne PROGETTO PUSH\_Façade: Verre FUMÉ semi-transparent sur cadre finition noire.  
 / Structure: LARICE CANNELLA décor bois / Plan: LARICE CANNELLA décor bois (40x30xH112 cm).

## FINITURE Finishing / Ausführungen / Finitions



LARICE CANNELLA

decorativo / decor /  
 Holzdekor / décor bois



VERDE ALPINO

gres lucido / glossy gres /  
 Feinsteinzeug glänzende / grès brillant



# 17 ACUTO / DUAL

IT CONTRASTI CROMATICI E VOLUMI DEFINITI COSTRUISCONO UNO SPAZIO DAL CARATTERE CONTEMPORANEO.

EN Chromatic contrasts and defined volumes shape a space with a contemporary character.

DE Farbkontraste und klar definierte Volumen gestalten einen Raum mit zeitgemäßem Charakter.

FR Des contrastes chromatiques et des volumes définis façonnent un espace au caractère contemporain.

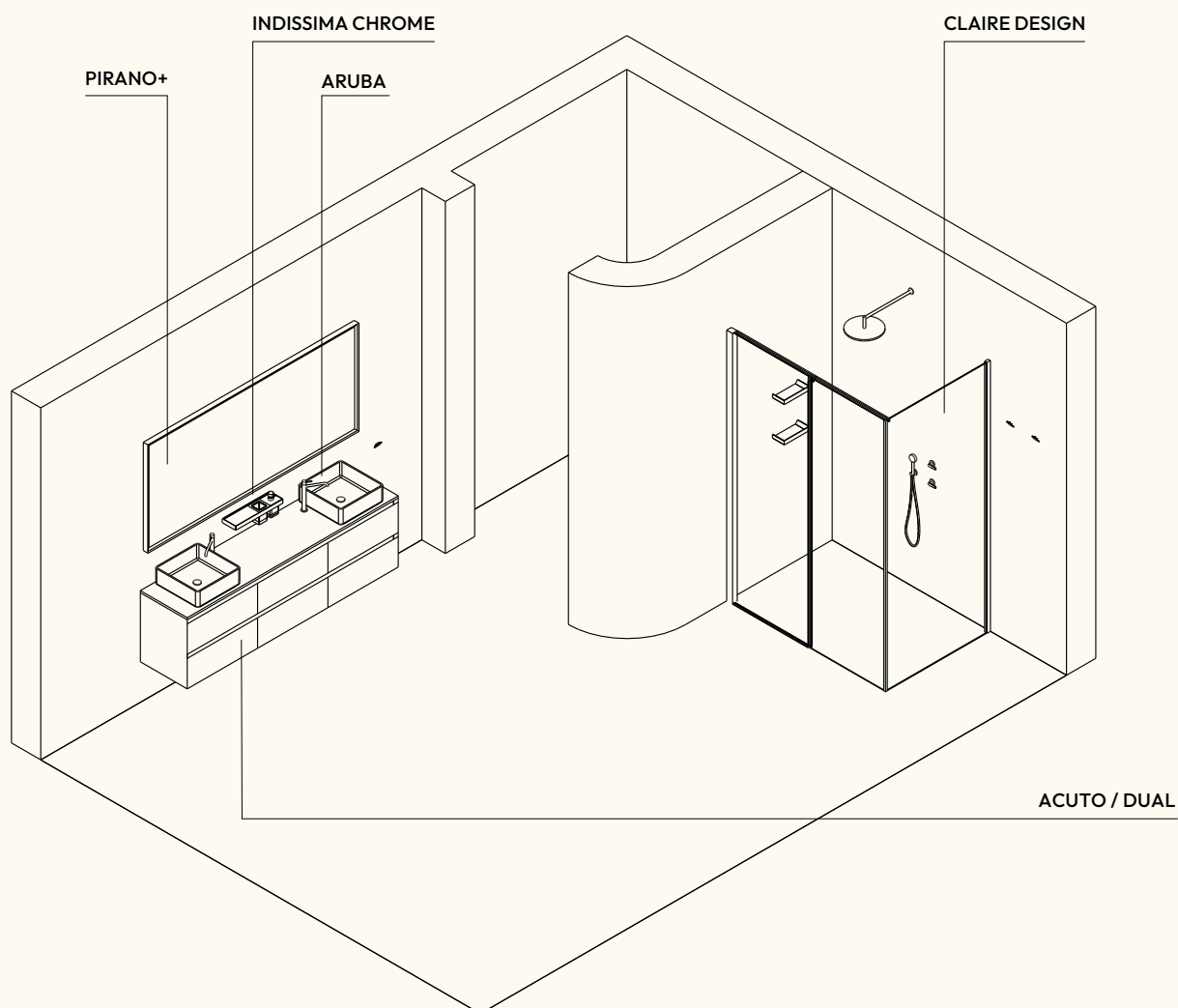







- IT **Frontali in laccato opaco Grafite e Platino con top coordinato in Grafite nella versione con doppia gola. Fianchi esterni laccati Grafite. Lavabo d'appoggio Aruba in solid surface bianco, abbinato agli accessori Indissima in cromo.**
- EN **Fronts in matt lacquer Grafite and Platino with coordinated Grafite top in the double-groove version. External sides lacquered Grafite. Aruba countertop basin in white solid surface, paired with Indissima accessories in chrome.**
- DE **Fronten in matt lackiert Grafite und Platino mit abgestimmten Abdeckplatten in Grafite in der Version mit doppelter Griffmulde. Außenseiten in Grafite lackiert. Aufsatzbecken Aruba aus weißem Solid Surface, kombiniert mit Accessoires Indissima in Chrom.**
- FR **Façades en laqué mat Grafite et Platino avec plan coordonné en Grafite dans la version à double prise de mains. Côtés extérieurs laqués Grafite. Vasque à poser Aruba en solid surface blanc, associée aux accessoires Indissima en chrome.**



- IT **Claire Design propone soluzioni pensate per elevare l'estetica e valorizzare lo stile dell'ambiente. La maniglia integrata contribuisce a definire un profilo più pulito ed essenziale, esaltando la linearità del design.**
- EN Claire Design offers solutions conceived to elevate aesthetics and enhance the style of the space. The integrated handle helps define a cleaner and more essential profile, highlighting the linearity of the design.
- DE Claire Design bietet Lösungen, die entwickelt wurden, um die Ästhetik zu steigern und den Stil des Raumes aufzuwerten. Der integrierte Griff trägt dazu bei, ein klareres und essenzielleres Profil zu definieren und die Linearität des Designs zu betonen.
- FR Claire Design propose des solutions conçues pour élever l'esthétique et valoriser le style de l'espace. La poignée intégrée contribue à définir un profil plus épuré et essentiel, en soulignant la linéarité du design.





## 17 ACUTO / DUAL

### PIRANO+

- IT Specchio con illuminazione\_Argento satinato.  
EN Mirror with lighting\_Satin silver.  
DE Lichtspiegel\_Satin Silber.  
FR Miroir avec éclairage\_Argent satiné.

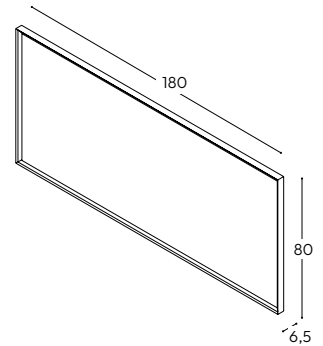

### INDISSIMA CHROME

- IT Accessori\_Cromato / Vetro satinato.  
EN Accessories\_Chrome / Satined Glass.  
DE Accessoires\_Verchromt / Satiniertes Glas.  
FR Accessoires\_Chromé / Verre satiné.

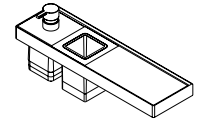

### ARUBA

- IT Lavabo da appoggio\_solid surface.  
EN Tabletop washbasin\_solid surface.  
DE Aufsatzbecken\_Solid Surface.  
FR Vasque à poser\_solid surface.

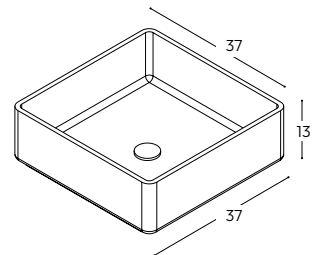

### ACUTO / DUAL

- IT Frontali\_GRAFITE laccato opaco // PLATINO laccato opaco.  
Struttura\_GRAFITE laccato opaco.  
Top\_GRAFITE laccato opaco.  
EN Fronts\_GRAFITE matt lacquered // PLATINO matt lacquered.  
Structure\_GRAFITE matt lacquered.  
Worktop\_GRAFITE matt lacquered.  
DE Fronten\_GRAFITE matt lackiert // PLATINO matt lackiert.  
Möbelkorpus\_GRAFITE matt lackiert.  
Abdeckplatte\_GRAFITE matt lackiert.  
FR Façades\_GRAFITE laqué mat // PLATINO laqué mat.  
Structure\_GRAFITE laqué mat.  
Plan\_GRAFITE laqué mat.

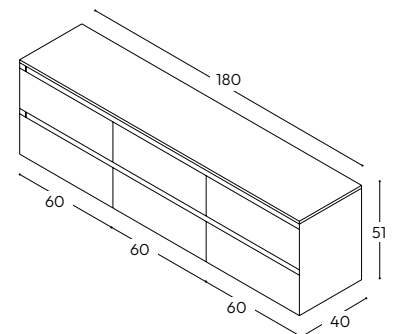

pag. 177

### CLAIRE DESIGN

- IT Parete doccia\_Porta battente con elemento fisso: GRAFITE / Vetro Trasparente (140x90xH200 cm).  
EN Shower enclosure\_Hinged door with in-line fixed panel: GRAFITE / Transparent Glass (140x90xH200 cm).  
DE Duschtrennung\_Drehflügeltür mit feststehendem Element: GRAFITE / Klarglas (140x90xH200 cm).  
FR Paroi de douche\_Porte battante avec élément fixe en ligne: GRAFITE / Verre Transparent (140x90xH200 cm).

## FINITURE Finishing / Ausführungen / Finitions

GRAFITE

laccato opaco / matt lacquered /  
matt lackiert / laqué mat

PLATINO

laccato opaco / matt lacquered /  
matt lackiert / laqué mat



# 18 ACUTO / PURO

IT LEGNO E HPL SI INCONTRANO TRA CALORE MATERICO E PRECISIONE FORMALE, DEFINENDO UN'ELEGANZA CONTEMPORANEA.

EN Wood and HPL meet between material warmth and formal precision, defining a contemporary elegance.

DE Holz und HPL begegnen sich zwischen materieller Wärme und formaler Präzision und definieren eine zeitgenössische Eleganz.

FR Le bois et le HPL se rencontrent entre chaleur matérielle et précision formelle, définissant une élégance contemporaine.

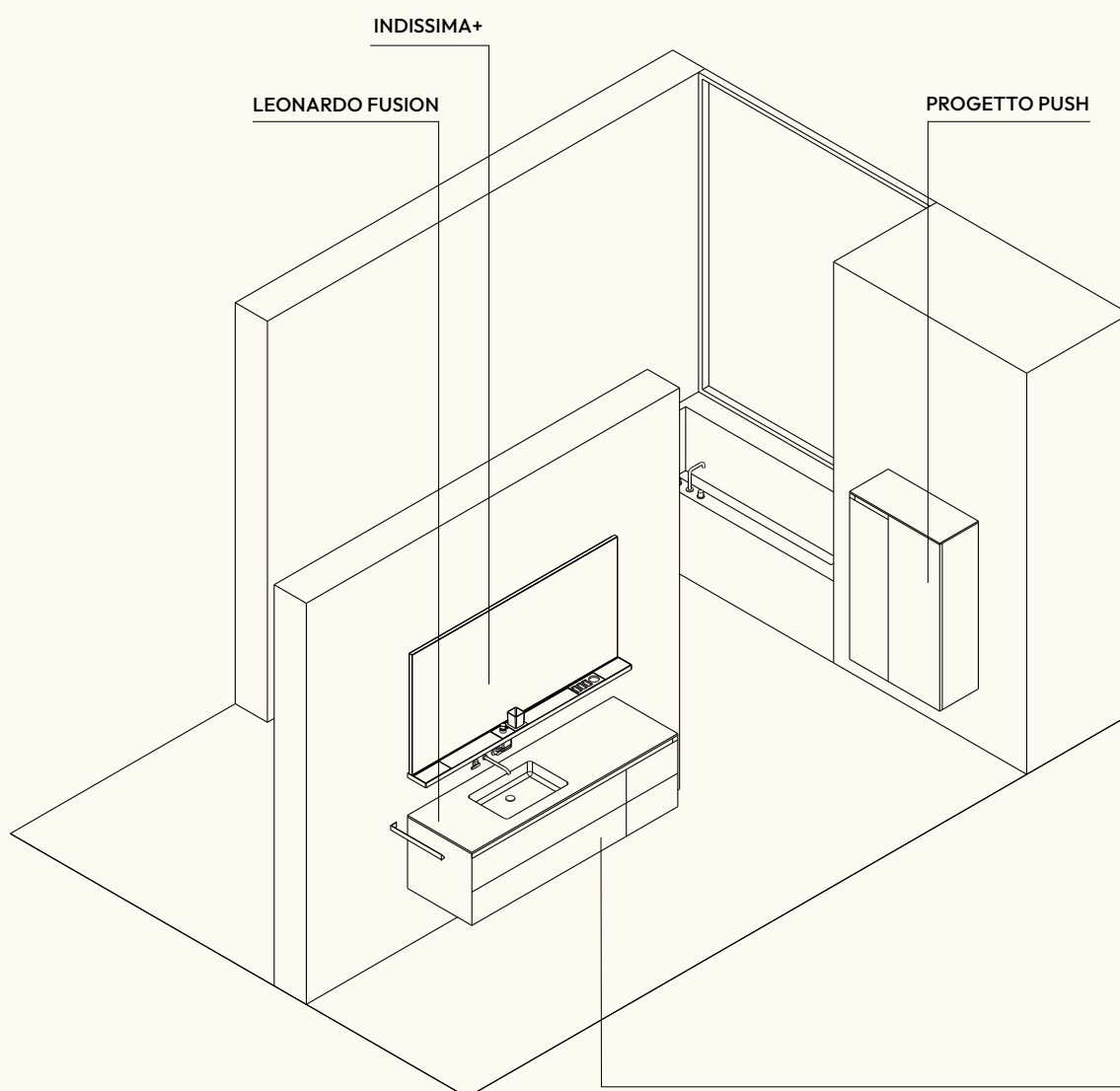

ACUTO / PURO







- IT **Frontali in Rovere Naturale impiallacciato. Lavabo integrato Leonardo Fusion con top in HPL Calacatta e vasca in ceramica bianca opaca. Specchio Indissima+ con mensola sottospeschio in finitura nero opaco e moduli mensola in HPL Calacatta.**
- EN Fronts in veneered Rovere Naturale. Integrated Leonardo Fusion basin with top in HPL Calacatta and basin in matt white ceramic. Indissima+ mirror with under-mirror shelf in matt black finish and shelf modules in HPL Calacatta.
- DE Fronten in furniertem Rovere Naturale. Integriertes Becken Leonardo Fusion mit Abdeckplatten aus HPL Calacatta und Becken aus matt weißer Keramik. Spiegel Indissima+ mit Unterspiegel-Ablage in matt Schwarz Ausführung und Ablagemodulen aus HPL Calacatta.
- FR Façades en Rovere Naturale plaqué. Vasque intégrée Leonardo Fusion avec plan en HPL Calacatta et cuve en céramique blanc mat. Miroir Indissima+ avec étagère sous miroir en finition noir mat et modules d'étagère en HPL Calacatta.



- IT **Coppia di colonne: la prima con frontali in Rovere Naturale impiallacciato; la seconda con apertura push, frontali in HPL Calacatta e telaio nero opaco.**
- EN Pair of tall units: the first with fronts in veneered Rovere Naturale; the second with push opening, fronts in HPL Calacatta and matt black frame.
- DE Paar Hochschränke: der erste mit Fronten in furniertem Rovere Naturale; der zweite mit Push-Öffnung, Fronten aus HPL Calacatta und Rahmen in matt Schwarz.
- FR Paire de colonnes : la première avec façades en Rovere Naturale plaqué ; la seconde avec ouverture push, façades en HPL Calacatta et cadre noir mat.





## 18 ACUTO / PURO

### INDISSIMA+

- IT Specchio con illuminazione\_Nero opaco.  
 EN Mirror with lighting\_Matt black.  
 DE Lichtspiegel\_Schwarz matt.  
 FR Miroir avec éclairage\_Noir mat.

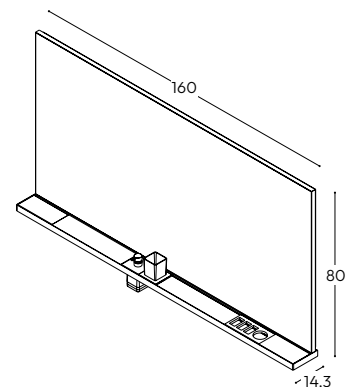

### INDISSIMA

- IT Accessori\_Nero opaco / CALACATTA HPL // Vetro satinato.  
 EN Accessories\_Matt black / CALACATTA HPL // Satined Glass.  
 DE Accessoires\_Schwarz matt / CALACATTA-HPL // Satiniertes Glas.  
 FR Accessoires\_Noir mat / HPL CALACATTA // Verre satiné.

### LEONARDO FUSION

- IT Lavabo integrato\_Piano: CALACATTA HPL / Vasca: ceramica.  
 EN Integrated washbasin\_Countertop: CALACATTA HPL / Basin: ceramic.  
 DE Integriertes Waschbecken\_Platte: CALACATTA-HPL / Waschbecken: Keramik.  
 FR Vasque intégrée\_Plan: HPL CALACATTA / Lavabo: céramique.

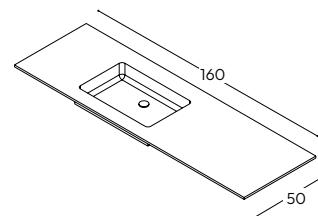

### ACUTO / PURO

- IT Frontali\_ROVERE NATURALE legno impiallacciato.  
 Struttura\_ROVERE NATURALE legno impiallacciato.  
 EN Fronts\_ROVERE NATURALE wood veneer.  
 Structure\_ROVERE NATURALE wood veneer.  
 DE Front\_ROVERE NATURALE Furnierholz.  
 Möbelkorpus\_ROVERE NATURALE Furnierholz.  
 FR Façades\_ROVERE NATURALE bois plaqué.  
 Structure\_ROVERE NATURALE bois plaqué.

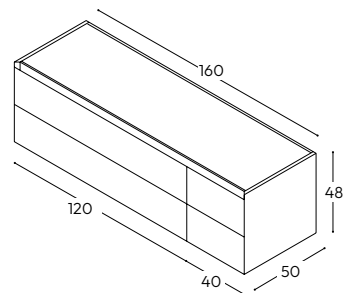

### pag. 187

- IT Colonne ACUTO\_Frontali e Struttura: ROVERE NATURALE legno impiallacciato (30x30xH112 cm).  
 Colonne PROGETTO PUSH\_Frontali: CALACATTA HPL, su telaio in finitura nero.  
 / Struttura: ROVERE NATURALE legno impiallacciato (40x30xH112 cm).  
 EN Columns ACUTO\_Fronts and Structure: ROVERE NATURALE wood veneer (30x30xH112 cm).  
 Column PROGETTO PUSH\_Fronts: CALACATTA HPL on frame in black finish.  
 / Structure: ROVERE NATURALE wood veneer (40x30xH112 cm).  
 DE Hochschränke ACUTO\_Fronten und Möbelkorpus: ROVERE NATURALE Furnierholz (30x30xH112 cm).  
 Hochschrank PROGETTO PUSH\_Fronten: CALACATTA-HPL mit schwarzem Rahmen.  
 / Möbelkorpus: ROVERE NATURALE Furnierholz (40x30xH112 cm).  
 FR Colonnes ACUTO\_Façade et Structure: ROVERE NATURALE bois plaqué (30x30xH112 cm).  
 Colonne PROGETTO PUSH\_Façade: HPL CALACATTA sur cadre finition noire.  
 / Structure: ROVERE NATURALE bois plaqué (40x30xH112 cm).

## FINITURE Finishing / Ausführungen / Finitions



ROVERE NATURALE

legno impiallacciato / wood veneer /  
 Furnierholz / bois plaqué

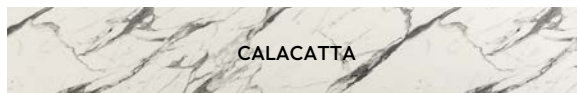

CALACATTA

HPL



# 19 ACUTO / MIDI

IT UN SEGNO PULITO E UNA MENSOLA  
SOSPESA DEFINISCONO LA ZONA  
BEAUTY CON ELEGANZA.

EN A clean line and a suspended shelf define the beauty area with elegance.

DE Eine klare Linie und eine schwebende Konsole definieren den Beauty-Bereich mit Eleganz.

FR Une ligne épurée et une tablette suspendue définissent l'espace beauty avec une élégance.

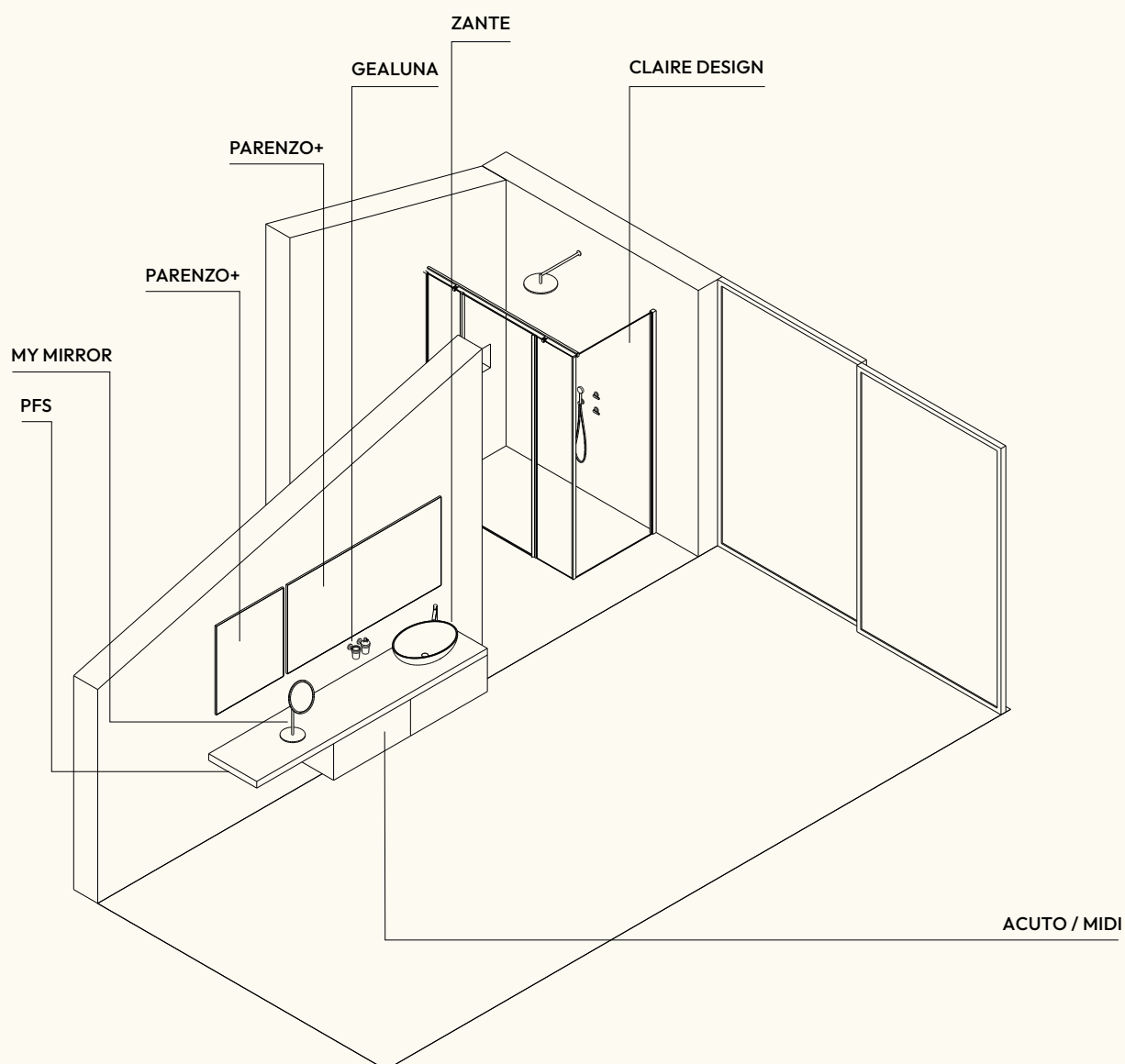









- IT** Frontali in laccato opaco Seta con consolle PFS (Piano Forte Spessore) da 6 cm di spessore in legno impiallacciato Rovere Testa di Moro. Lavabo d'appoggio Zante, finitura Seta. Accessori Gealuna in finitura opaco Seta.
- EN** Fronts in matt lacquer Seta with PFS console (shelf) 6 cm thick in Rovere Testa di Moro wood veneer. Zante countertop basin, Seta finish. Gealuna accessories in matt Seta finish.
- DE** Fronten in matt lackiert Seta mit Konsole PFS (Ablage) 6 cm stark in Rovere Testa di Moro Furnierholz. Aufsatzbecken Zante, Ausführung Seta. Accessoires Gealuna in matt Seta Ausführung.
- FR** Façades en laqué mat Seta avec console PFS (étagère) de 6 cm d'épaisseur en Rovere Testa di Moro bois plaqué. Vasque à poser Zante, finition Seta. Accessoires Gealuna en finition mat Seta.

- IT **In Claire Design la maniglia integrata valorizza la linearità del design, creando un profilo pulito ed essenziale.**
- EN In Claire Design the integrated handle enhances the linearity of the design, creating a clean and essential profile.
- DE Im Claire Design unterstreicht der integrierte Griff die Linearität des Designs und schafft ein klares und essentielles Profil.
- FR En Claire Design, la poignée intégrée valorise la linéarité du design, créant un profil épuré et essentiel.





## 19 ACUTO / MIDI

### PARENZO+

- IT Specchio con illuminazione\_Metal grey.  
EN Mirror with lighting\_Metal grey.  
DE Lichtspiegel\_Metal grey.  
FR Miroir avec éclairage\_Metal grey.

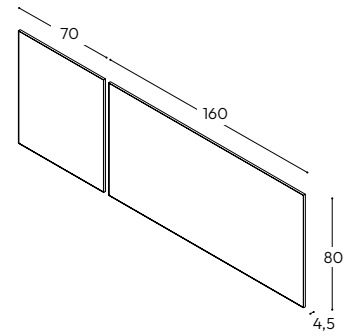

### GEALUNA

- IT Accessori\_SETA / Vetro Trasparente.  
EN Accessories\_SETA / Transparent Glass.  
DE Accessoires\_SETA / Transparentes Glas.  
FR Accessoires\_SETA / Verre Transparent.



### ZANTE

- IT Lavabo da appoggio\_SETA, mineralguss.  
EN Tabletop washbasin\_SETA, mineral marble.  
DE Aufsatzbecken\_SETA, Mineralguss.  
FR Vasque à poser\_SETA, marbre de synthèse.

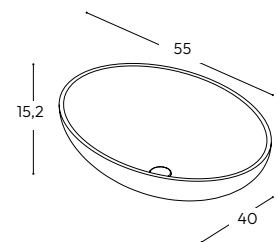

### ACUTO / MIDI

- IT Frontali\_SETA laccato opaco.  
Struttura\_SETA laccato opaco.  
PFS\_ROVERE TESTA DI MORO legno impiallacciato.  
EN Fronts\_SETA matt lacquer.  
Structure\_SETA matt lacquer.  
PFS\_ROVERE TESTA DI MORO wood veneer.  
DE Fronten\_SETA matt lackiert.  
Möbelkorpus\_SETA matt lackiert.  
PFS\_ROVERE TESTA DI MORO Furnierholz.  
FR Façades\_SETA laqué mat.  
Structure\_SETA laqué mat.  
PFS\_ROVERE TESTA DI MORO bois plaqué.

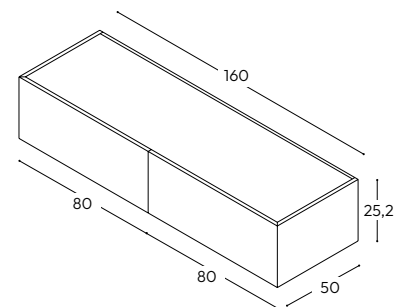

pag. 197

### CLAIRE DESIGN

- IT Parete doccia\_Porta battente con 2 elementi fissi: SETA / Vetro Trasparente (160x90xH200 cm).  
EN Shower enclosure\_Hinged door with 2 in-line fixed panels: SETA / Transparent Glass (160x90xH200 cm).  
DE Duschtrennung\_Drehtür mit 2 feststehenden Elementen in Linie: SETA / Klarglas (160x90xH200 cm).  
FR Paroi de douche\_Porte battante avec 2 éléments fixes en ligne: SETA / Verre Transparent (160x90xH200 cm).

## FINITURE Finishing / Ausführungen / Finitions

ROVERE TESTA DI MORO

legno impiallacciato / wood veneer /  
Furnierholz / bois plaqué

SETA

laccato opaco / matt lacquered /  
matt lackiert / laqué mat



# 20 ACUTO / DUAL

IT VOLUMI E COLORE COSTRUISCONO  
UN RITMO VISIVO CHE DEFINISCE UNA  
COMPOSIZIONE DAL CARATTERE  
CONTEMPORANEO.

EN Volumes and color create a visual rhythm that defines a composition with a contemporary character.

DE Volumen und Farbe schaffen einen visuellen Rhythmus, der eine Komposition mit zeitgemäßem Charakter definiert.

FR Volumes et couleur créent un rythme visuel qui définit une composition au caractère contemporain.

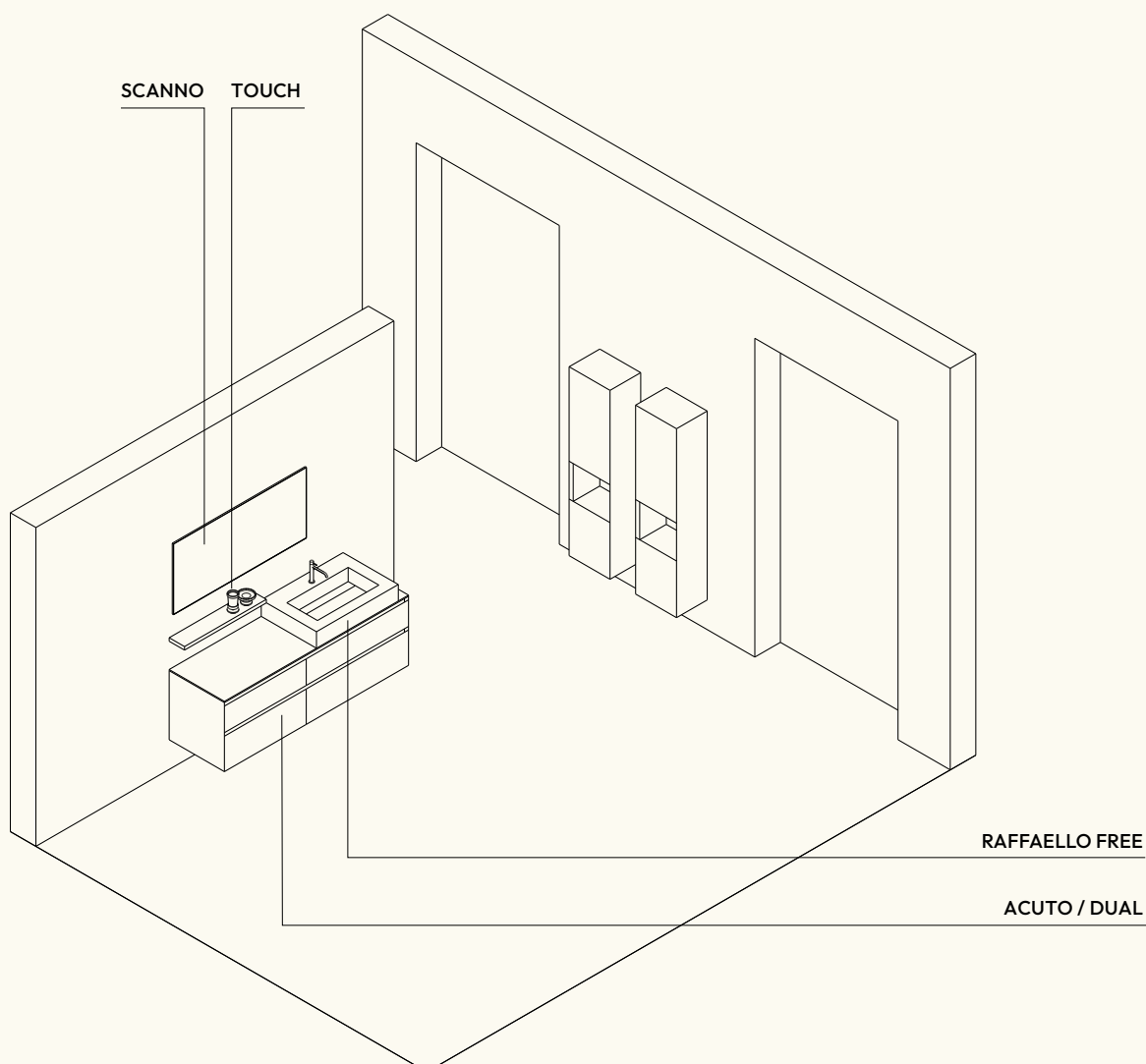







- IT **Frontali in decorativo Noce Canaletto con top e mensola coordinati, abbinati al lavabo Raffaello Free in gres finitura Terra di Siena, completano gli accessori Touch.**
- EN Fronts in Noce Canaletto decor finish with coordinated top and shelf, paired with the Raffaello Free basin in gres Terra di Siena finish, completed by Touch accessories.
- DE Fronten in Dekor Noce Canaletto mit abgestimmten Abdeckplatten und Ablage, kombiniert mit dem Becken Raffaello Free aus Feinsteinzeug in Ausführung Terra di Siena, ergänzt durch Accessoires Touch.
- FR Façades en décor Noce Canaletto avec plan et étagère coordonnés, associées à la vasque Raffaello Free en gres finition Terra di Siena, complétées par les accessoires Touch.



- IT **Colonne in finitura laccato opaco Cannella, con vano a giorno con illuminazione a LED ambientale.**
- EN Tall units in matt lacquer Cannella finish, with open compartment featuring ambient LED lighting.
- DE Hochschränke in matt lackiert Cannella Ausführung mit offenem Fach mit ambienster LED-Beleuchtung.
- FR Colonnes en finition laqué mat Cannella avec niche ouverte dotée d'un éclairage LED d'ambiance.





## 20 ACUTO / DUAL

### SCANNO

- IT Specchio d'arredo\_Metal grey.  
EN Mirror\_Metal grey.  
DE Spiegel\_Metal grey.  
FR Miroir\_Metal grey.

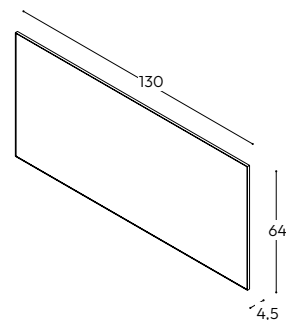

### TOUCH

- IT Accessori\_Cromato / Vetro satinato.  
EN Accessories\_Chrome / Satined Glass.  
DE Accessoires\_Verchromt / Satiniertes Glas.  
FR Accessoires\_Chromé / Verre satiné.

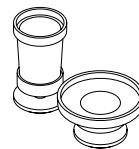

### RAFFAELLO FREE

- IT Consolle con lavabo integrato\_TERRA DI SIENA, gres opaco.  
EN Console with integrated washbasin\_TERRA DI SIENA, matt gres.  
DE Integriertes Waschbecken als Freistehende Version\_TERRA DI SIENA, Feinsteinzeug matt.  
FR Console avec lavabo intégré\_TERRA DI SIENA, grès mat.

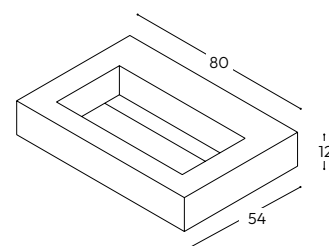

### ACUTO / DUAL

- IT Frontali\_NOCE CANALETTO decorativo.  
Struttura\_NOCE CANALETTO decorativo.  
Top\_NOCE CANALETTO decorativo.  
EN Fronts\_NOCE CANALETTO decor.  
Structure\_NOCE CANALETTO decor.  
Worktop\_NOCE CANALETTO decor.  
DE Fronten\_NOCE CANALETTO Holzdekor.  
Möbelkorpus\_NOCE CANALETTO Holzdekor.  
Abdeckplatte\_NOCE CANALETTO Holzdekor.  
FR Façades\_NOCE CANALETTO décor bois.  
Structure\_NOCE CANALETTO décor bois.  
Plan\_NOCE CANALETTO décor bois.

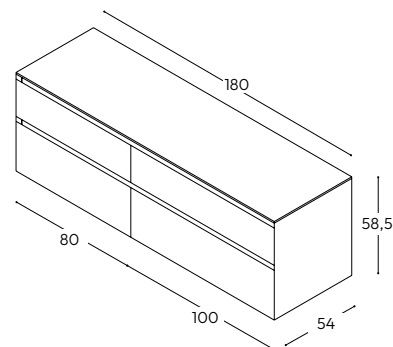

### pag. 207

- IT Colonne con vani a giorno\_Frontali: CANNELLA laccato opaco.  
/ Struttura: CANNELLA laccato opaco (40x30xH160 cm).  
EN Columns and open compartments\_Fronts: CANNELLA matt lacquered.  
/ Structure: CANNELLA matt lacquered (40x30xH160 cm).  
DE Hochschränke und offene Fächer\_Fronten: CANNELLA matt lackiert.  
/ Möbelkorpus: CANNELLA matt lackiert (40x30xH160 cm).  
FR Colonnes et compartiments ouverts\_Façades: CANNELLA laqué mat.  
/ Structure\_CANNELLA laqué mat (40x30xH160 cm).

## FINITURE Finishing / Ausführungen / Finitions

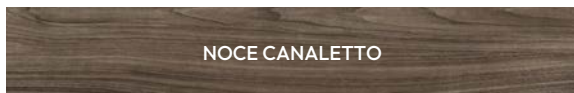

NOCE CANALETTO

decorativo / decor /  
Holzdekor / décor bois



TERRA DI SIENA

gres opaco / matt gres /  
Feinsteinzeug matt / grès mat

# FINITURE

Finishing / Finitions / Ausführungen



## LEGNO IMPIALLACCIATO

Wood veneer / Echtholz furnier / Placage bois



024 **Rovere chiaro**



016 **Rovere naturale**



025 **Rovere tabacco**



026 **Rovere cenere**



027 **Rovere selenio**

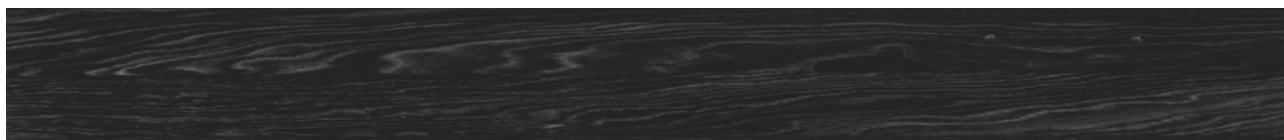

028 **Rovere testa di moro**



017 **Noce naturale**

## **MOBILI – DECORATIVI TINTA LEGNO E MATERICI**

FURNITURE – Wood-tone and textured decor finishes / MÖBEL – Dekorative Holz- und Materialtöne /  
MEUBLES – Décor bois et matières texturées



LL 177 **Abete primavera**



LL 176 **Quercia nature**



LL 178 **Abete estate**



LL 190 **Rovere rustico**



LL 199 **Rovere miele**



LL 150 **Olmo nature**



LL 180 **Larice Cannella**



LL 181 **Pino Rosso**



LL 182 **Rovere Corteccia**

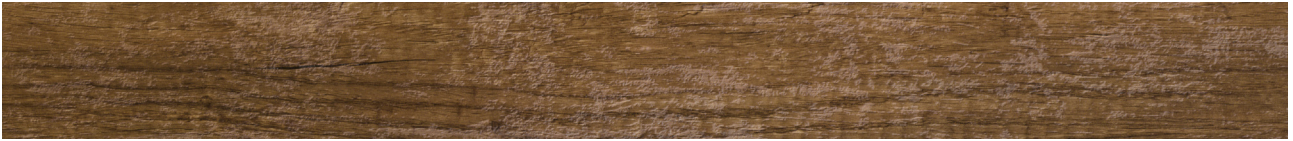

LL 159 Olmo tabak



LL 192 Sabbia



LL 191 Rovere crudo



LL 179 Tavolato

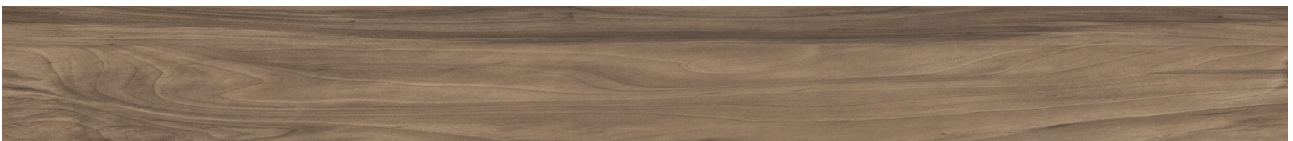

LL 175 Noce biondo



LL 156 Iron



LL 193 Noce canaletto



LL 194 Rovere carbone

## MOBILI – COLORI IN LACCATO LUCIDO OPPURE OPACO

FURNITURE – Colours in matt and glossy lacquer / MÖBEL – Farben in Matt und glänzend lackiert  
 / MEUBLES – Couleurs en laqué mat et brillant

<b>Bianco</b>		<b>Perla</b>		<b>Cemento</b>	
LC 402	LG 202	LC 515	LG 315	LC 681	LG 216
<b>Seta</b>		<b>Titanio</b>		<b>Ardesia</b>	
LC 925	LG 595	LC 516	LG 316	LC 500	LG 300
<b>Grafite</b>		<b>Nero</b>		<b>Bianco Latte</b>	
LC 690	LG 246	LC 633	LG 705	LC 484	LG 288
<b>Avorio</b>		<b>Platino</b>		<b>Creta</b>	
LC 514	LG 314	LC 922	LG 592	LC 684	LG 219
<b>Terra di Luna</b>		<b>Visone</b>		<b>Avana</b>	
LC 472	LG 785	LC 512	LG 312	LC 919	LG 589
<b>Bruno</b>		<b>Ambra</b>		<b>Camoscio</b>	
LC 913	LG 222	LC 503	LG 303	LC 626	LG 209
<b>Cannella</b>		<b>Cacao</b>		<b>Porcellana</b>	
LC 325	LG 525	LC 513	LG 313	LC 507	LG 307
<b>Cipria</b>		<b>Marsala</b>		<b>Lavanda</b>	
LC 504	LG 304	LC 501	LG 301	LC 509	LG 309
<b>Rosso rubino</b>		<b>Cuoio bruciato</b>		<b>Terracotta</b>	
LC 481	LG 788	LC 327	LG 527	LC 326	LG 526

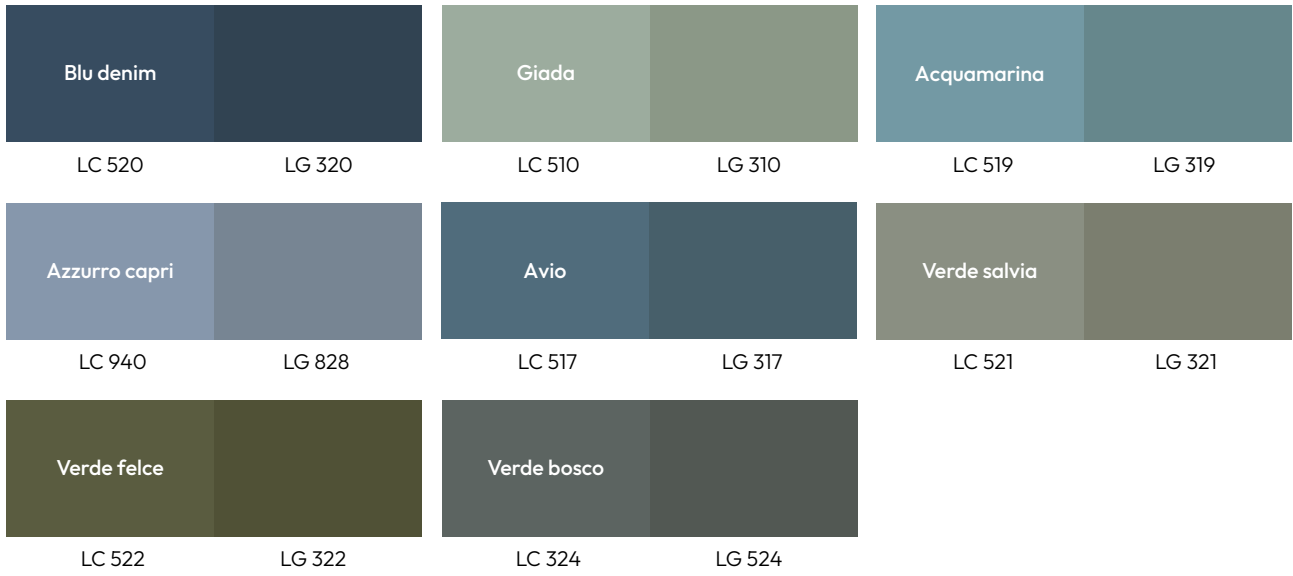

# FINITURE DEI PIANI TOP

Top finishes / Arbeitsplatten-oberflächen / Finitions des plans de travail



## PIANO MARMO LUCIDO E OPACO

Countertop polished and matt marble / Polierte und matte Marmorplatte / Plan marbre poli et mat



MA 001 Q Bianco Dolomite lucido / MA 001 S Bianco Dolomite opaco



MA 007 Q Breccia Capraia lucido / MA 007 S Breccia Capraia opaco



MA 003 Q Taj Mahal lucido / MA 003 S Taj Mahal opaco



MA 004 Q Fior di pesco lucido / MA 004 S Fior di pesco opaco

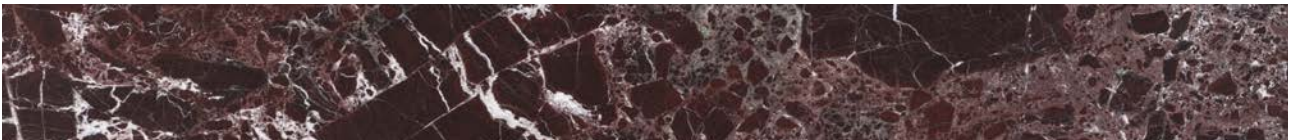

MA 005 Q Rosso Lepanto lucido / MA 005 S Rosso Lepanto opaco



MA 006 Q Verde Lepanto lucido / MA 006 S Verde Lepanto opaco



MA 002 Q Nero Marquinia lucido / MA 002 S Nero Marquinia opaco

## PIANO GRES OPACO

Countertop matt gres / Matte Feinsteinzeugplatte / Plan grès mat

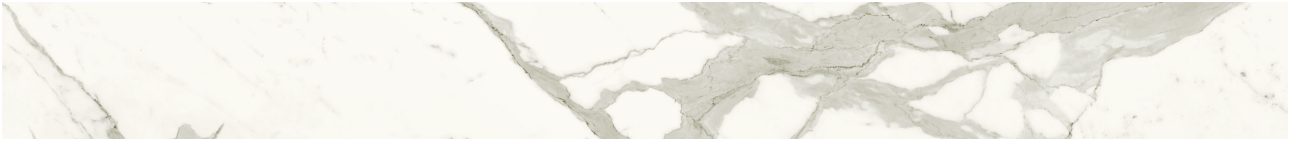

GR 197 Bianco statuario opaco



GR 204 Bianco naturale fusion opaco



GR 199 Cristallo oro opaco



GR 201 Travertino bianco opaco



GR 206 Travertino argento opaco



GR 203 Crema diamante opaco



GR 215 Calce opaco



GR 216 Terra di Siena opaco

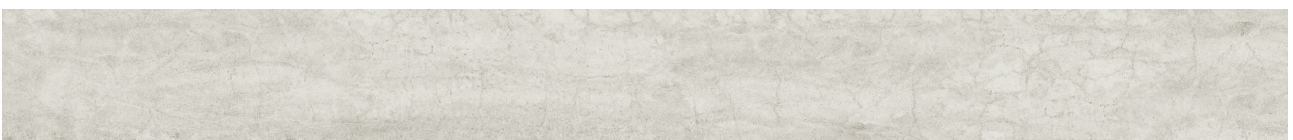

GR 195 Pietra naturale opaco



GR 196 Pietra d'Iseo opaco



GR 198 Pietra grigia opaco



GR 211 Nero greco opaco



GR 194 Nero agadez opaco

## PIANO IN GRES LUCIDO

Countertop in glossy gres / Glänzende Feinsteinzeugplatte / Plan en grès brillant

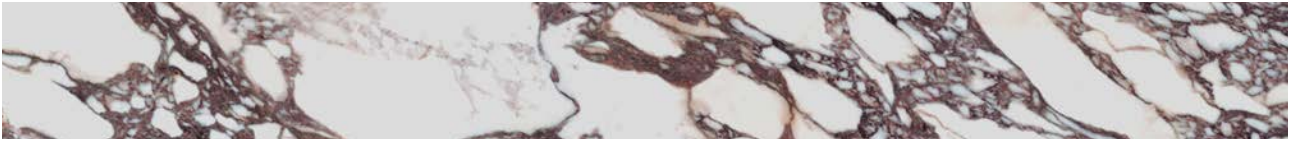

GR 217 Calacatta Viola lucido

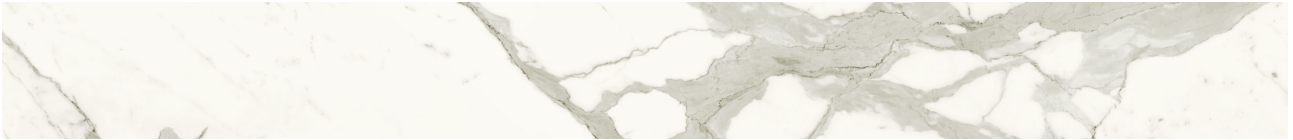

GR 192 Bianco statuario lucido



GR 212 Cristallo oro lucido

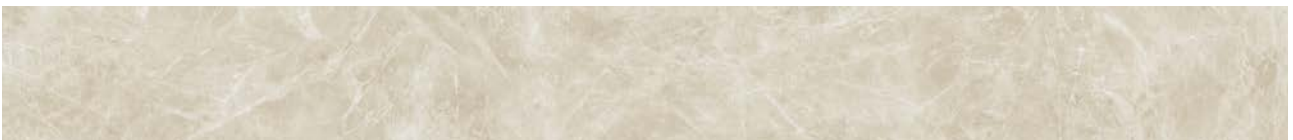

GR 213 Crema diamante lucido



GR 205 Onice lucido



GR 191 Pietra grigio lucido

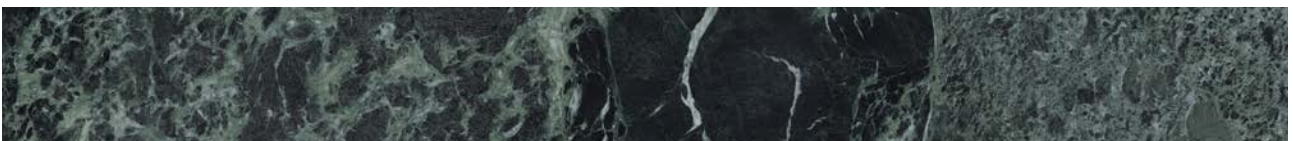

GR 214 Verde alpino lucido

## **QUARZO**

Quartz / Quarz / Quartz



**QZ 002 Bianco nuvola**



**QZ 001 Sabbia**

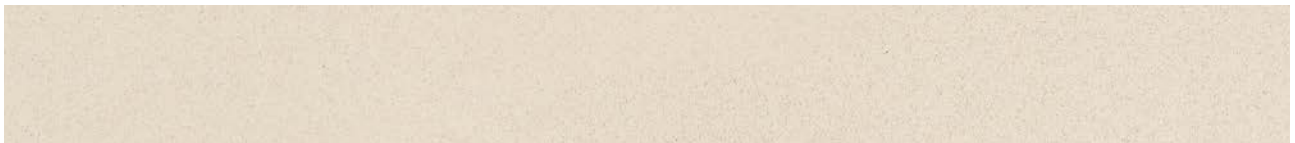

**QZ 005 Beige chiaro**



**QZ 003 Grigio nuvola**

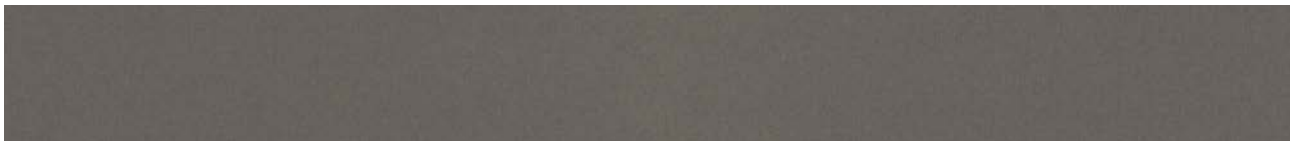

**QZ 004 Nuvola scuro**



**QZ 006 Marmo nero**

## PIANO IN HPL

Countertop in HPL / HPL-Arbeitsplatte / Plan en HPL



HP 176 Malta



HP 195 Geo



HP 177 Porfido



HP 182 Calacatta



HP 178 Pietra scura



HP 192 Yule



HP 181 Texas

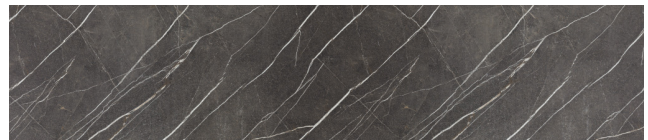

HP 189 Grigio venato



HP 194 Corten



HP 174 Yard



HP 191 **Travertino**

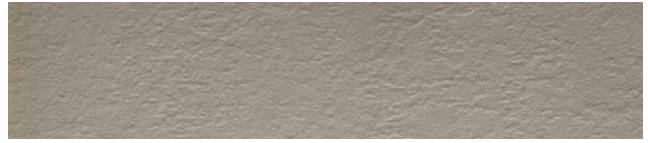

HP 179 **Pietra chiara**



HP 185 **Rovere wafer**

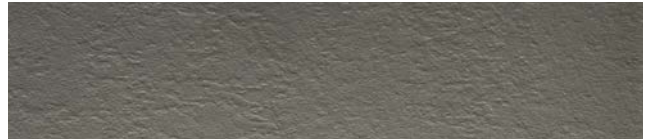

HP 175 **Cemento scuro**



HP 187 **Rovere di Slavonia**

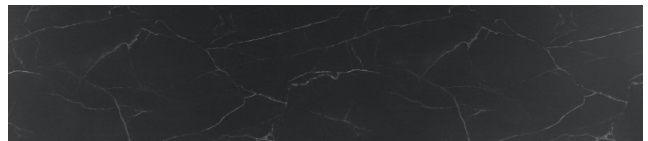

HP 188 **Nero cretese**



HP 186 **Noce scuro**



HP 180 **Lava**



HP 183 **Oregon**

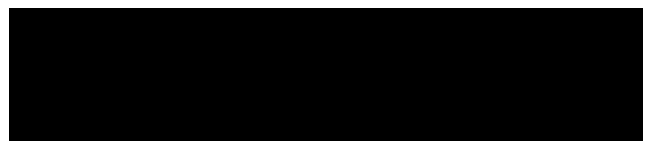

HP 184 **Fenix®nero**

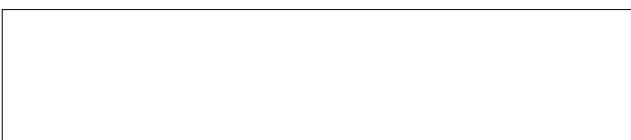

HP 196 **Fenix®bianco**

## TOP VETRO LACCATI E SATINATI

Lacquered and frosted glass tops / Top aus lackiertem und satiniertem glas / Plans verre laqués et satinés

		
TP 500 Bianco *	TP 615 Perla *	TP 519 Cemento *
		
TP 536 Seta *	TP 616 Titanio	TP 600 Ardesia *
		
TP 523 Grafite	TP 521 Nero	TP 509 Bianco latte *
		
TP 614 Avorio *	TP 535 Platino *	TP 520 Creta *
		
TP 503 Terra di luna *	TP 612 Visone *	TP 534 Avana *
		
TP 532 Bruno	TP 603 Ambra *	TP 515 Camoscio *
		
TP 525 Cannella	TP 613 Cacao	TP 607 Porcellana *
		
TP 604 Cipria *	TP 601 Marsala	TP 609 Lavanda
		
TP 506 Rosso rubino	TP 527 Cuoio bruciato	TP 526 Terracotta



TP 320 Blu denim



TP 610 Giada



TP 619 Acquamarina



TP 541 Azzurro capri



TP 617 Avio



TP 321 Verde salvia



TP 322 Verde felce



TP 524 Verde bosco

I colori dei top in versione SATINATA (integrati Dharma e top lineari) sono disponibili esclusivamente nelle finiture indicate con (\*) /  
The colors of the tops in SATIN finish (Dharma integrated and linear tops) are available exclusively in the finishes indicated with (\*) /  
Die Farben der Platten in SATINIERTER Ausführung (Dharma integrierte-WT und Abdeckplatten) sind ausschließlich in den mit (\*)  
gekennzeichneten Ausführungen erhältlich / Les couleurs des plans en finition SATINÉE (plans intégrés Dharma et plans linéaires) sont  
disponibles exclusivement dans les finitions indiquées par (\*)



The Art of Creating a Home

# YOUR OWN COLOR

- IT Inda propone un'unica soluzione cromatica per tutta la stanza da bagno, con colori opachi selezionati per:
- le pareti doccia WALK IN, CLAIRE, CLAIRE NP, CLAIRE DESIGN e PRAIA DESIGN
  - gli accessori LEA, GEALUNA, MY LOVE e MY SECRET
  - gli specchi PIRANO EVO, PIRANO, SPALATO, ZARA, LISSA, LISSA MX, MAGGIORE e TENNO da abbinare alle stesse finiture mobili e piani top, ai lavabi integrati GIOTTO COLOR, TIZIANO COLOR, TIZIANO LAUNDRY e ai lavabi in appoggio in mineralguss.
- EN Inda suggests an entire colour solution for your bathroom, with selected matt shades for:
- WALK IN, CLAIRE, CLAIRE NP, CLAIRE DESIGN and PRAIA DESIGN shower enclosures
  - LEA, GEALUNA, MY LOVE and MY SECRET accessories
  - PIRANO EVO, PIRANO, SPALATO, ZARA, LISSA, LISSA MX, MAGGIORE and TENNO mirrors to be combined with the same finishes of cabinets and worktops, GIOTTO COLOR, TIZIANO COLOR, TIZIANO LAUNDRY integrated washbasins and tabletop washbasins in mineral marble.
- DE Inda bietet eine einfarbige Lösung für das gesamte Badezimmer, mit ausgewählten matten Farben, an für:
- die Duschkabinen WALK IN, CLAIRE, CLAIRE NP, CLAIRE DESIGN und PRAIA DESIGN
  - das Zubehör der Serien LEA, GEALUNA, MY LOVE und MY SECRET
  - den PIRANO EVO, PIRANO, SPALATO, ZARA, LISSA, LISSA MX, MAGGIORE und TENNO-Spiegel kombinierbar mit den gleichen Ausführungen der Möbel und - Abdeckplatten, mit den integrierten Waschtischen GIOTTO COLOR, TIZIANO COLOR, TIZIANO LAUNDRY und zu den Aufsatzwaschbecken aus Mineralguss.
- FR Inda propose une solution de couleur unique pour toute la salle de bain, avec couleurs opaques sélectionnées pour :
- les parois de douche WALK IN, CLAIRE, CLAIRE NP, CLAIRE DESIGN et PRAIA DESIGN
  - les accessoires LEA, GEALUNA, MY LOVE et MY SECRET
  - les miroirs PIRANO EVO, PIRANO, SPALATO, ZARA, LISSA, LISSA MX, MAGGIORE et TENNO à combiner avec les mêmes finitions des meubles, plans top des meubles, avec les lavabos GIOTTO COLOR, TIZIANO COLOR, TIZIANO LAUNDRY intégré et aux lavabos en mineralguss.

Your Own Color Brochure

V



# COMPOSIZIONI ACUTO

ACUTO Compositions / ACUTO Zusammensetzungen / Compositions ACUTO

## 01 ACUTO / PURO

PAGES 006 / 015

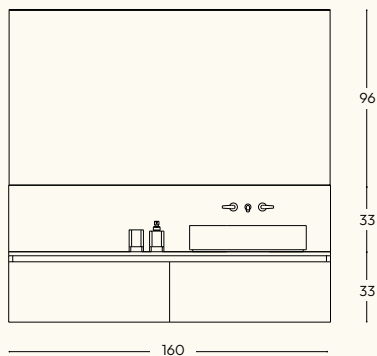

## 02 ACUTO / MIDI

PAGES 016 / 025

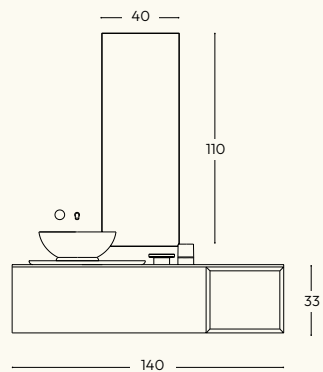

## 03 ACUTO / PURO

PAGES 026 / 035

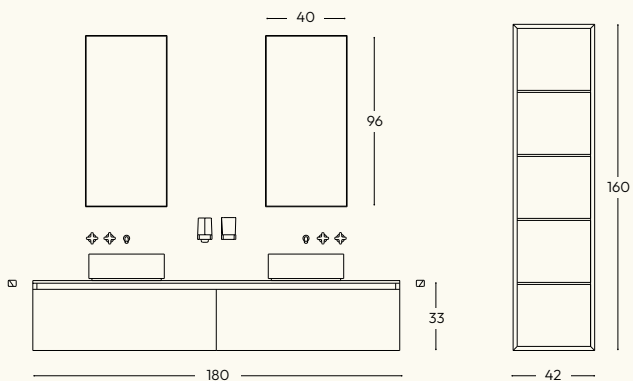

## 04 ACUTO / PURO

PAGES 036 / 045

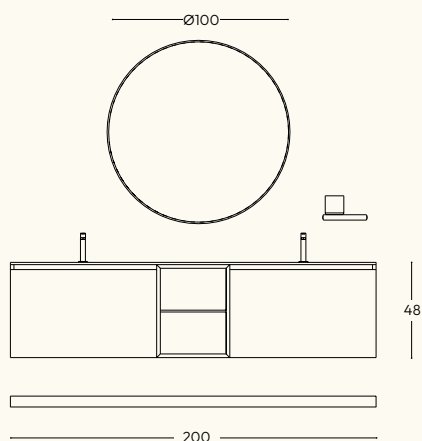

## 05 ACUTO / MIDI

PAGES 046 / 055

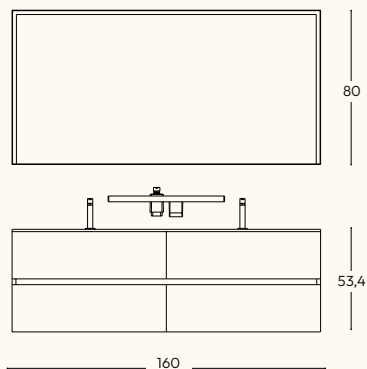

## 06 ACUTO / PURO

PAGES 056 / 065

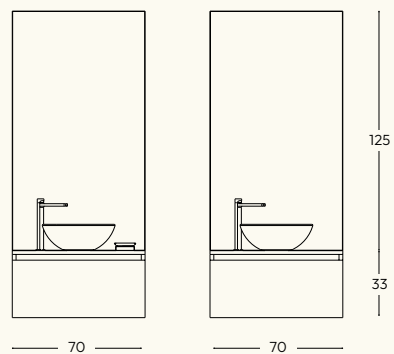

**07 ACUTO / PURO**

PAGES 066 / 075

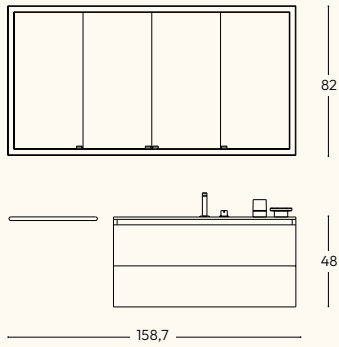

**08 ACUTO / PURO**

PAGES 076 / 085

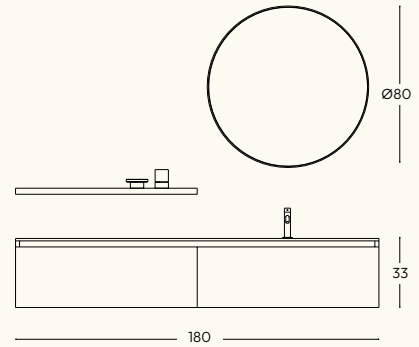

**09 ACUTO / PURO**

PAGES 086 / 095

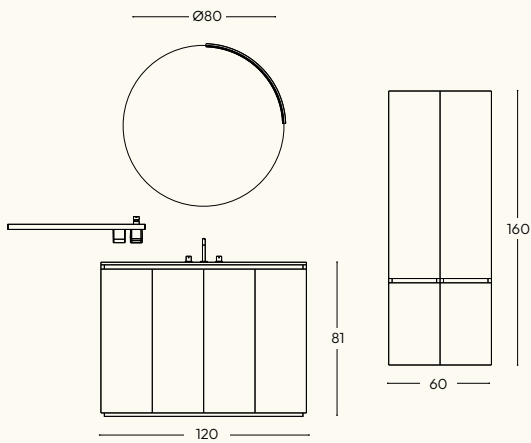

**10 ACUTO / MIDI**

PAGES 096 / 105

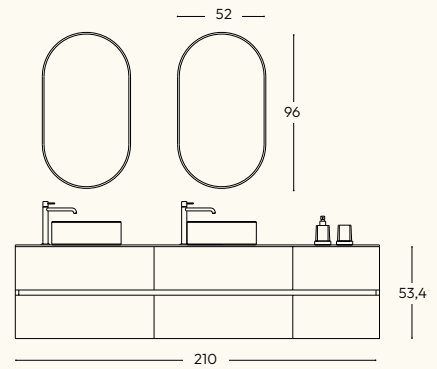

**11 ACUTO / PURO**

PAGES 106 / 115

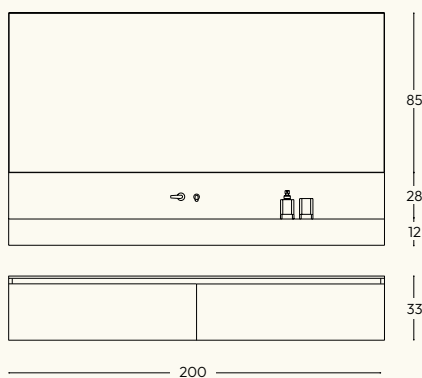

**12 ACUTO / PURO**

PAGES 116 / 127

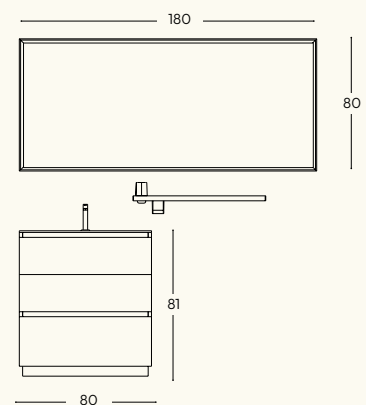

# COMPOSIZIONI ACUTO

DIVO Compositions / DIVO Zusammensetzungen / Compositions DIVO

## 13 ACUTO / MIDI

PAGES 128 / 137

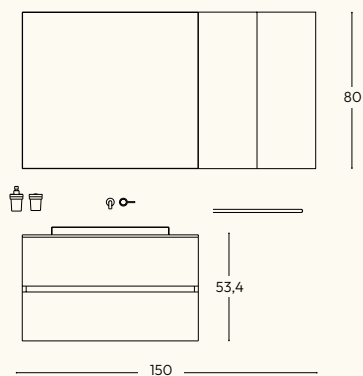

## 14 ACUTO / PURO

PAGES 138 / 147

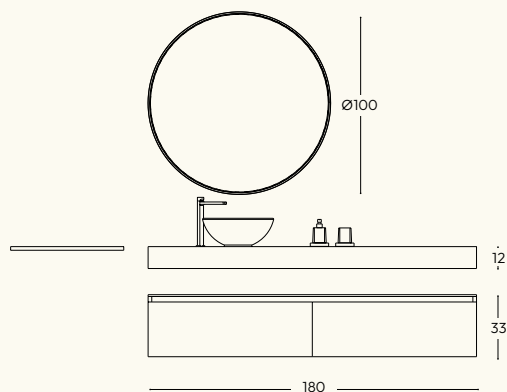

## 15 ACUTO / DUAL

PAGES 148 / 159

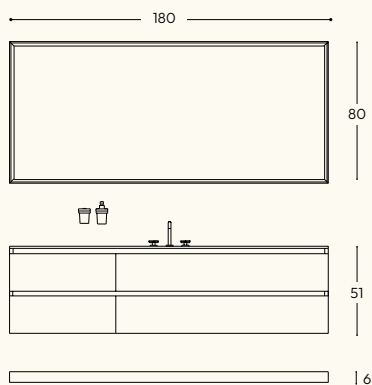

## 16 ACUTO / PURO

PAGES 160 / 169

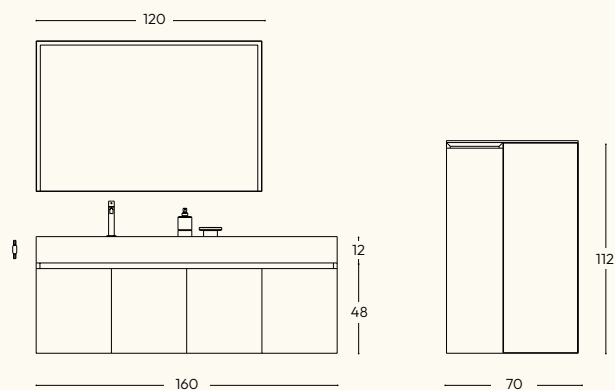

## 17 ACUTO / DUAL

PAGES 170 / 179

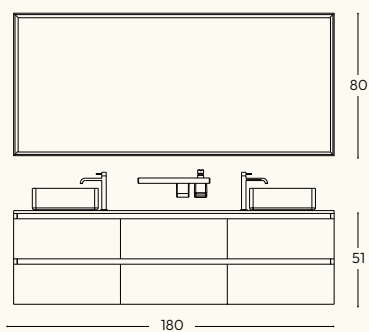

## 18 ACUTO / PURO

PAGES 180 / 189

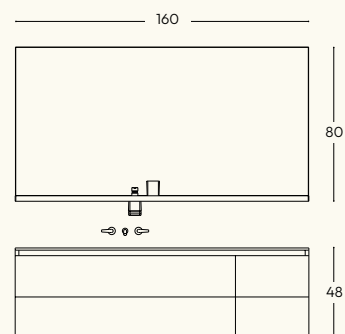

## 19 ACUTO / MIDI

PAGES 190 / 199

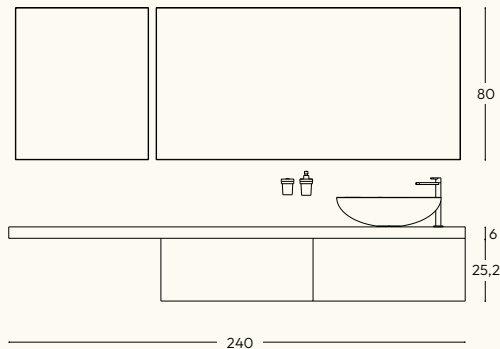

## 20 ACUTO / DUAL

PAGES 200 / 209

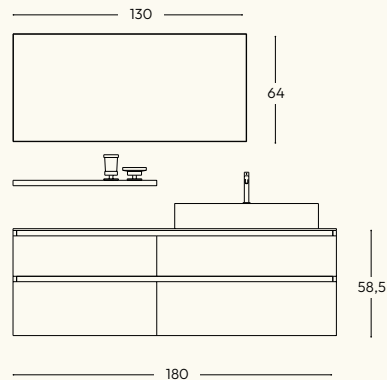

**IT** **STRUTTURA:** finita sui lati esterni, interno antracite.

**CASSETTI:** cassetti con sponda metallica ad estrazione totale e chiusura rallentata in colore antracite.

**FRONTALI:** decorativo, laccato opaco, lucido e impiallacciato legno.

**TOP:** piani lineari per lavabo da appoggio o con lavabo integrato come da collezione Inda.

**EN** **STRUCTURE:** finished on the external sides, anthracite interior.

**DRAWERS:** drawers with metal sides, full extension and soft-close, in anthracite colour.

**FRONTS:** decor, matt lacquered, gloss lacquered and wood veneered.

**TOP:** linear tops for countertop basin or with integrated basin as per Inda collection.

**DE** **STRUKTUR:** außen fertig, Innenraum anthrazit.

**SCHUBKÄSTEN:** Schubkästen mit Metallzarge, Vollauszug und Soft-Close in Farbe Anthrazit.

**FRONTEN:** dekorativ, matt lackiert, glänzend lackiert und Holzfurnier.

**ABDECKPLATTEN:** lineare Platten für Aufsatzbecken oder mit integriertem Becken gemäß Inda-Kollektion.

**FR** **STRUCTURE :** finition sur les côtés extérieurs, intérieur anthracite.

**TIROIRS :** tiroirs avec côtés métalliques à extraction totale et fermeture amortie en couleur anthracite.

**FRONTAUX :** décoratif, laqué mat, laqué brillant et plaqué bois.

**PLAN :** plans linéaires pour vasque à poser ou avec vasque intégrée selon la collection Inda.

La fedeltà cromatica dei campioni può discostarsi dalla realtà: la cartella colori ha un valore indicativo /  
The chromatic accuracy of the samples can diverge from the reality: the colour chart has an approximate value /  
Die Farbgenauigkeit der Muster kann abweichen: Die Farbkarte gilt nur als Richtwert /  
La fidélité des couleurs des échantillons peut être différente de la réalité: la palette de couleur a une valeur indicative.

© 2026 INDA SpA — Tutti i diritti riservati.  
È vietata la riproduzione, anche parziale, dei contenuti presenti in questa brochure senza l'espressa autorizzazione di INDA SpA.

© 2026 INDA S.p.A. — All rights reserved.  
No part of this brochure may be reproduced, stored or transmitted in any form or by any means, electronic, mechanical, photocopying or otherwise, without the prior written permission of INDA S.p.A.

© 2026 INDA SpA — Alle Rechte vorbehalten.  
Die Vervielfältigung, auch auszugsweise, der in dieser Broschüre enthaltenen Inhalte ist ohne ausdrückliche Genehmigung der INDA SpA untersagt.

© 2026 INDA SpA — Tous droits réservés.  
Toute reproduction, même partielle, des contenus figurant dans cette brochure est interdite sans l'autorisation expresse de INDA SpA.

#### CREDITS

Art Direction, Set Design,  
Styling, Images: [studioraum.it](http://studioraum.it) / [Inda\\_uff\\_mkt](#)  
Graphic Design: [studioraum.it](http://studioraum.it) / [Mattietto Federica](#) / [Inda\\_uff\\_mkt](#)

**INDA France SAS**  
735 Rue Georges Claude  
Zone Industrielle Les Milles  
13290 Aix-en-Provence  
[commandes.france@inda.net](mailto:commandes.france@inda.net)

---

#### INDA SpA

Via dell'Industria, 163  
I-24040 Pagazzano (BG)

**Bathroom Furniture**  
Via Postumia Ovest, 72  
I-31048 Olmi di San Biagio di Callalta (TV)

[www.inda.net](http://www.inda.net)  
[info@inda.net](mailto:info@inda.net)

P.Iva: ITO3868760962  
Registro Imprese di Bergamo: 03868760962  
Numero REA: BG – 386581  
Capitale Sociale: Euro 4.000.000,00 i.v.





